

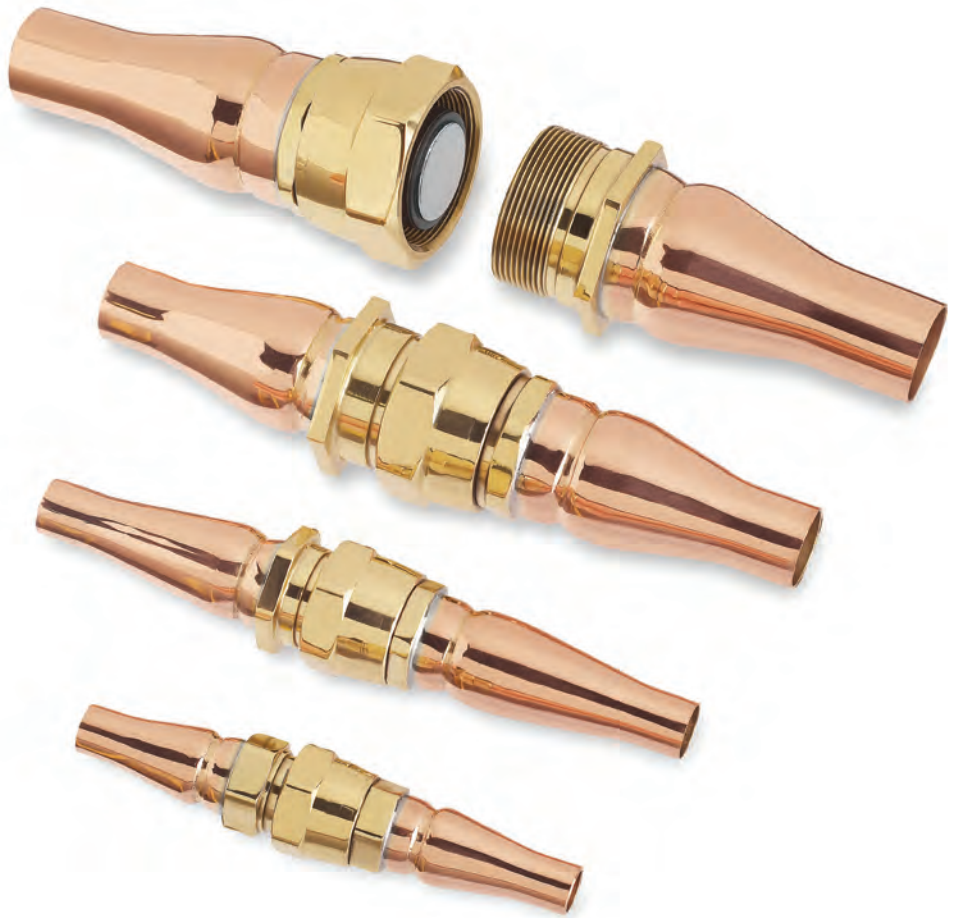

aerospace  
climate control  
electromechanical  
filtration  
fluid & gas handling  
hydraulics  
pneumatics  
process control  
sealing & shielding



# Couplings - OEM

Catalog OEM-1, June 2017

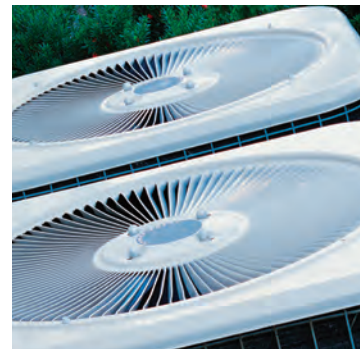

ENGINEERING YOUR SUCCESS.

# Couplings

## Table of Contents

<b>Introduction to Parker Couplings</b> . . . . .	<b>3</b>
<b>System Couplings</b>	
5400 Series Self-Sealing Steel Couplings . . . . .	4
5500 Series Self-Sealing Brass Couplings . . . . .	10
5700 Series One-Shot™ Brass Couplings . . . . .	19
FD57 Series Stub Kit Couplings . . . . .	25
<b>Process Couplings</b>	
RC01C Series Automotive (R134a) Service Couplings . . . . .	28
RC01YF Series Automotive (1234YF) Service Couplings . . . . .	30
<b>Terms of Sale with Warranty Limitations.</b> . . . . .	<b>32</b>

### Parker Series System Couplings are Available with ZoomLine!



Parker 5400, 5500 and 5700 Series System Couplings are available with ZoomLine. Refer to Parker Catalog J for more information on custom OEM assemblies.

#### **⚠ WARNING – USER RESPONSIBILITY**

**Failure or improper selection or improper use of the products described herein or related items can cause death, personal injury and property damage.**

This document and other information from Parker Hannifin Corporation, its subsidiaries and authorized distributors provide product or system options for further investigation by users having technical expertise.

The user, through its own analysis and testing, is solely responsible for making the final selection of the system and components and assuring that all performance, endurance, maintenance, safety and warning requirements of the application are met. The user must analyze all aspects of the application, follow applicable industry standards, and follow the information concerning the product in the current product catalog and in any other materials provided from Parker or its subsidiaries or authorized distributors.

To the extent that Parker or its subsidiaries or authorized distributors provide component or system options based upon data or specifications provided by the user, the user is responsible for determining that such data and specifications are suitable and sufficient for all applications and reasonably foreseeable uses of the components or systems.

#### **OFFER OF SALE**

The items described in this document are hereby offered for sale by Parker Hannifin Corporation, its subsidiaries or its authorized distributors. This offer and its acceptance are governed by the provisions stated in the detailed "Offer of Sale" elsewhere in this document or available at [www.parker.com](http://www.parker.com).

Catalog OEM-1 Couplings, June 2017 supersedes Catalog OEM-1 Couplings, January 2015 and all prior publications.

# Introduction to Parker Couplings

Parker Hannifin has the broadest coupling product offering in the market. Whether it's quick connect, self-sealing upon disconnection, or brass or steel construction, Parker has what you need. With applications ranging from room air-conditioners to cryogenic pumps, Parker has the product you are looking for.

This complete line approach allows Parker to develop value-added assemblies that will reduce SKUs and increase production throughput. Combine this with the outstanding services Parker offers and anything is possible.

## The Parker Advantage

- Broadest product line
- Technology leader
- Value-added assembly
- E-Commerce
- Supply chain management



**5400 Series Self Sealing  
Steel Couplings**

page 4



**5500 Series Self-Sealing  
Brass Couplings**

page 10

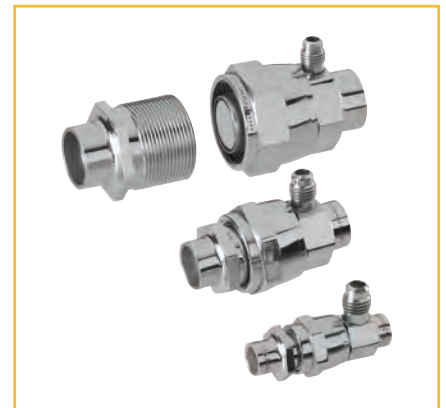

**5700 Series One-Shot™  
Brass Coupling**

page 19



**RC01C Series Automotive  
R134a Service Couplings**

page 28



**RC01YF Series Automotive  
1234YF Service Couplings**

page 30

# 5400 Series Self-Sealing Steel Couplings

Parker's 5400 self-sealing steel couplings are used in fluid-transfer applications for easy maintenance on refrigeration and air conditioning systems. The couplings also allow for pre-charging of units for easy installation. Applications can include marine refrigeration and air conditioning systems, along with cryogenic units.



## Applications

- General fluid-transfer applications
- Marine refrigerant and air conditioning systems
- Cryogenic systems

## Base Product Part Number

- 5400-S2 Male coupling half
- 5400-S5 Female coupling half

## Features and Benefits

- Self-sealing upon disconnection maintains minimum air inclusion and fluid loss.
- Field repairable allowing an internal valve to be replaced, if needed.
- Steel coupling provides durability.
- A variety of mechanical end connections available, along with sweat connections, to provide options for installation.
- Multiple sizes available, along with bulkhead mounting options, to match a coupling to a unique application.
- RoHS Compliant
- Compatible with most refrigerants, including R-410A

## Specifications

All sizes are field repairable.

Standard Material:

Final seal – Neoprene™\*  
 Seal – Neoprene™\*  
 Body – Zinc-plated steel  
 Adapter – Zinc-plated steel or brass

Temp. Rating: -40°F to +250°F  
 -40°C to 177°C

\* Contact Parker for alternative elastomer sealing options.

## Agency Approvals

U.L. listed; File No: SA7511

## Specifications — English Units

Dash Size	Part Description	Operating Pressure (psi)	Minimum Burst Pressure (psi)	Air Inclusion cc/Connect	Maximum Fluid Loss cc/Disconnect	Static Connect (psig)	Coupled (oz./yr)	Uncoupled Without Cap/Plug (oz./yr)	Uncoupled With Cap/Plug (oz./yr)	Vacuum (in. Hg.)	Rated Flow (gpm)
-4	Male half	2500	7500	0.1	0.05	150	< 0.25	< 0.5	< 0.25	-	-
-4	Female half	500	1500	0.1	0.05	150	< 0.25	< 0.5	< 0.25	-	-
-4	Whole coupling	3000	9000	0.1	0.05	150	< 0.25	< 0.5	< 0.25	28	14
-8	Male half	1750	5200	0.1	0.1	150	< 0.25	< 0.5	< 0.25	-	-
-8	Female half	750	2250	0.1	0.1	150	< 0.25	< 0.5	< 0.25	-	-
-8	Whole coupling	1750	5200	0.1	0.1	150	< 0.25	< 0.5	< 0.25	28	14
-12	Male half	800	2100	0.3	0.1	150	< 0.25	< 0.5	< 0.25	-	-
-12	Female half	750	2250	0.3	0.1	150	< 0.25	< 0.5	< 0.25	-	-
-12	Whole coupling	700	2100	0.3	0.1	150	< 0.25	< 0.5	< 0.25	28	35
-16	Male half	700	2100	0.5	0.2	150	< 0.25	< 0.5	< 0.25	-	-
-16	Female half	300	900	0.5	0.2	150	< 0.25	< 0.5	< 0.25	-	-
-16	Whole coupling	700	2100	0.5	0.2	150	< 0.25	< 0.5	< 0.25	28	75

## Specifications — Metric Units

Dash Size	Part Description	Operating Pressure (bar)	Minimum Burst Pressure (bar)	Air Inclusion CC/Connect	Maximum Fluid Loss CC/Disconnect	Static Connect (bar)	Coupled (g./yr)	Uncoupled Without Cap/Plug (g./yr)	Uncoupled With Cap/Plug (g./yr)	Vacuum (mm. Hg.)	Rated Flow (lpm)
-4	Male half	179.5	517.2	0.1	0.05	10.3	7.1	14.2	7.1	-	-
-4	Female half	34.5	103.4	0.1	0.05	10.3	7.1	14.2	7.1	-	-
-4	Whole coupling	206.9	620.7	0.1	0.05	10.3	7.1	14.2	7.1	711	52.9
-8	Male half	120.7	358.6	0.1	0.1	10.3	7.1	14.2	7.1	-	-
-8	Female half	51.7	155.2	0.1	0.1	10.3	7.1	14.2	7.1	-	-
-8	Whole coupling	120.7	358.6	0.1	0.1	10.3	7.1	14.2	7.1	711	52.9
-12	Male half	55.2	144.8	0.3	0.1	10.3	7.1	14.2	7.1	-	-
-12	Female half	51.7	155.2	0.3	0.1	10.3	7.1	14.2	7.1	-	-
-12	Whole coupling	48.3	144.8	0.3	0.1	10.3	7.1	14.2	7.1	711	132.4
-16	Male half	48.3	144.8	0.5	0.2	10.3	7.1	14.2	7.1	-	-
-16	Female half	20.7	62.1	0.5	0.2	10.3	7.1	14.2	7.1	-	-
-16	Whole coupling	48.3	144.8	0.5	0.2	10.3	7.1	14.2	7.1	711	283.8

# Performance Data

**Liquid Line  
Pressure Drop vs. Mass Flow  
Refrigerant R22**

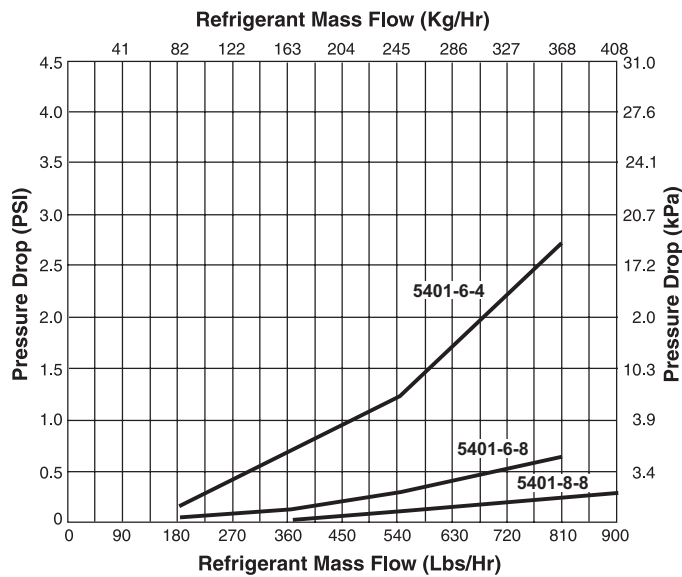

5401-6-4 — 1/4" Coupling Body (-04) with 3/8" (-06) Copper Connection, R22  
 5401-6-8 — 1/2" Coupling Body (-06) with 3/8" (-08) Copper Connection, R22  
 5401-8-8 — 1/2" Coupling Body (-08) with 1/2" (-08) Copper Connection, R22

**Pressure Drop Versus Flow**

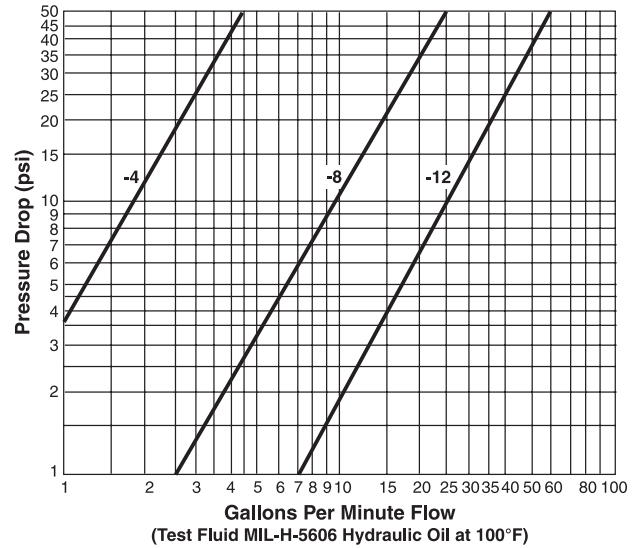

(Test Fluid MIL-H-5606 Hydraulic Oil at 100°F)

**Suction Line  
Pressure Drop vs. Mass Flow  
Refrigerant R22**

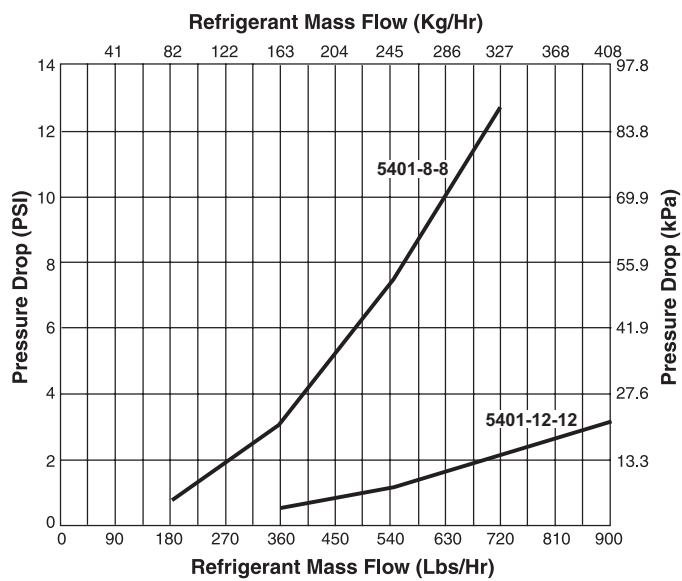

5401-8-8 — 1/2" Coupling Body (-08) with 1/2" (-08) Copper Connection, R22  
 5401-12-12 — 3/4" Coupling Body (-12) with 3/4" (-12) Copper Connection, R22

# Dimension Data

## 5400-S2 Male Half — No Adapter

Part Number Neoprene	Coupling Size	T1 Thread	A		H1 Hex		T2 Thread
			Inches	mm	Inches	mm	
5400-S2-4	-4	5/8-18 UNF	1.08	27.4	0.75	19.0	1/2-20 UNF
5400-S2-8	-8	1-20 UNEF	1.37	34.8	1.13	28.7	7/8-20 UNEF
5400-S2-12	-12	1 7/16-16 UN	1.74	44.2	1.63	41.4	1 1/4-18 UNEF
5400-S2-16	-16	1 3/4-16 UN	1.83	46.4	1.88	47.7	1 19/32-20 UNS

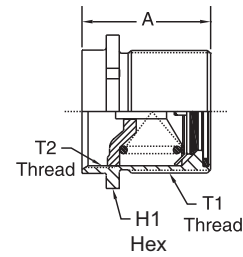

## 5400-S5 Female Half — No Adapter

Part Number Neoprene	Coupling Size	T1 Thread	A		H1 Hex		H2 Hex		T2 Thread
			Inches	mm	Inches	mm	Inches	mm	
5400-S5-4	-4	5/8-18 UNF	1.16	29.5	0.63	16.0	0.75	19.0	1/2-20 UNF
5400-S5-8	-8	1-20 UNEF	1.63	41.4	1.00	25.4	1.19	30.2	7/8-20 UNEF
5400-S5-12	-12	1 7/16-16 UN	2.13	54.1	1.38	35.0	1.63	41.4	1 1/4-18 UNEF
5400-S5-16	-16	1 3/4-16 UN	2.37	60.2	1.75	44.4	2.00	50.8	1 19/32-20 UNS

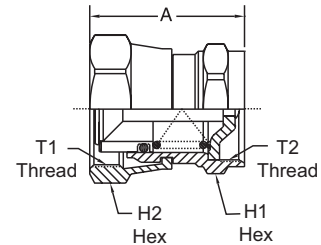

## 5401-S14 Female Half — Braze Tubing Adapter

Part Number Neoprene	Coupling Size	Copper Size Inches	A		H1 Hex		H2 Hex		H3 Hex	
			Inches	mm	Inches	mm	Inches	mm	Inches	mm
5401-S14-4-4	-4	1/4 (-4)	1.60	40.6	0.63	16.0	0.75	19.0	0.63	16.0
5401-S14-6-4	-4	3/8 (-6)	1.60	40.6	0.63	16.0	0.75	19.0	0.63	16.0
5401-S14-6-8	-8	3/8 (-6)	2.00	50.8	1.00	25.4	1.19	30.2	1.00	25.4
5401-S14-8-8	-8	1/2 (-8)	2.00	50.8	1.00	25.4	1.19	30.2	1.00	25.4
5401-S14-10-8	-8	5/8 (-10)	2.00	50.8	1.00	25.4	1.19	30.2	1.00	25.4
5401-S14-10-12	-12	5/8 (-10)	2.86	72.5	1.38	35.0	1.63	41.4	1.38	35.0
5401-S14-12-12	-12	3/4 (-12)	2.86	72.5	1.38	35.0	1.63	41.4	1.38	35.0
5401-S14-14-12	-12	7/8 (-14)	2.86	72.5	1.38	35.0	1.63	41.4	1.38	35.0
5401-S14-14-16	-16	7/8 (-14)	3.34	84.8	1.75	44.4	2.00	50.8	1.75	44.4
5401-S14-16-16	-16	1 (-16)	3.34	84.8	1.75	44.4	2.00	50.8	1.75	44.4
5401-S14-18-16	-16	1-1/8 (-18)	3.34	84.8	1.75	44.4	2.00	50.8	1.75	44.4

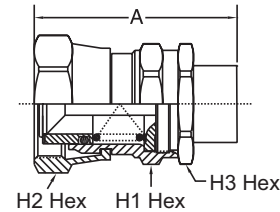

## 5401-S17 Male Half — Braze Tubing Adapter with Jam Nut

Part Number Neoprene	Coupling Size	Copper Size Inches	A		H1 Hex		H2 Hex		H3 Hex	
			Inches	mm	Inches	mm	Inches	mm	Inches	mm
5401-S17-4-4	-4	1/4 (-4)	1.52	38.6	0.75	19.0	0.63	16.0	0.75	19.0
5401-S17-6-4	-4	3/8 (-6)	1.52	38.6	0.75	19.0	0.63	16.0	0.75	19.0
5401-S17-6-8	-8	3/8 (-6)	1.75	44.4	1.13	28.7	1.00	25.4	1.19	30.2
5401-S17-8-8	-8	1/2 (-8)	1.75	44.4	1.13	28.7	1.00	25.4	1.19	30.2
5401-S17-10-8	-8	5/8 (-10)	1.75	44.4	1.13	28.7	1.00	25.4	1.19	30.2
5401-S17-10-12	-12	5/8 (-10)	2.47	62.7	1.63	41.4	1.38	35.0	1.56	39.6
5401-S17-12-12	-12	3/4 (-12)	2.47	62.7	1.63	41.4	1.38	35.0	1.56	39.6
5401-S17-14-12	-12	7/8 (-14)	2.47	62.7	1.63	41.4	1.38	35.0	1.56	39.6
5401-S17-14-16	-16	7/8 (-14)	2.80	71.1	1.88	47.7	1.75	44.4	2.00	50.8
5401-S17-16-16	-16	1 (-16)	2.80	71.1	1.88	47.7	1.75	44.4	2.00	50.8
5401-S17-18-16	-16	1-1/8 (-18)	2.80	71.1	1.88	47.7	1.75	44.4	2.00	50.8

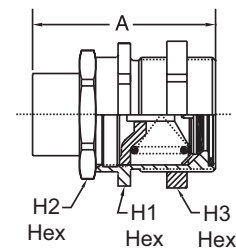

# Dimension Data

## 5401 Complete Coupling — Braze Tubing Adapter

Part Number Neoprene	Coupling Size	Copper Size Inches	A	
			Inches	mm
5401-4-4	-4	1/4 (-4)	2.85	72.4
5401-6-4	-4	3/8 (-6)	2.85	72.4
5401-6-8	-8	3/8 (-6)	3.37	85.6
5401-8-8	-8	1/2 (-8)	3.37	85.6
5401-10-8	-8	5/8 (-10)	3.37	85.6
5401-10-12	-12	5/8 (-10)	4.74	120.4
5401-12-12	-12	3/4 (-12)	4.74	120.4
5401-14-12	-12	7/8 (-14)	4.74	120.4
5401-14-16	-16	7/8 (-14)	5.52	140.2
5401-16-16	-16	1 (-16)	5.52	140.2
5401-18-16	-16	1-1/8 (-18)	5.52	140.2
5401-22-16	-16	1-3/8 (-22)	5.52	140.2

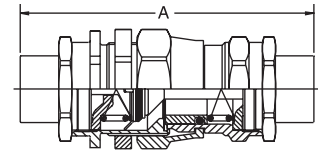

## 5410-S17 Male Half — SAE 37° (JIC)

Part Number Neoprene	Coupling Size	Adapter Size	T1 Thread	A		H1 Hex		H2 Hex		T2 Thread
				Inches	mm	Inches	mm	Inches	mm	
5410-S17-6-4	-4	-6	5/8-18 UNF	1.89	48.0	0.75	19.0	0.63	16.0	9/16-18 UNF
5410-S17-6-8	-8	-6	1-20 UNEF	2.18	55.3	1.13	28.7	1.00	25.4	9/16-18 UNF
5410-S17-8-8	-8	-8	1-20 UNEF	2.28	57.9	1.13	28.7	1.00	25.4	3/4-16 UNF
5410-S17-10-12	-12	-10	1 7/16-16 UN	2.75	69.8	1.63	41.4	1.38	35.0	7/8-14 UNF
5410-S17-12-12	-12	-12	1 7/16-16 UN	2.86	72.6	1.63	41.4	1.38	35.0	1 1/16-12 UN
5410-S17-16-16	-16	-16	1 3/4-16 UN	2.99	75.9	1.88	47.7	1.75	44.4	1 5/16-12 UN

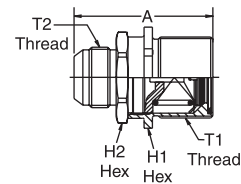

## 5410-S14 Female Half — SAE 37° (JIC)

Part Number Neoprene	Coupling Size	Adapter Size	T1 Thread	A		H1		H2 Hex		H3 Hex		T2 Thread
				Inch.	mm	Inch.	mm	Inch.	mm	Inch.	mm	
5410-S14-6-4	-4	-6	5/8-18 UNF	1.13	28.7	0.63	16.0	0.75	19.0	0.63	16.0	9/16-18 UNF
5410-S14-6-8	-8	-6	1-20 UNEF	1.63	41.4	1.00	25.4	1.19	30.2	1.00	25.4	9/16-18 UNF
5410-S14-8-8	-8	-8	1-20 UNEF	1.63	41.4	1.00	25.4	1.19	30.2	1.00	25.4	3/4-16 UNF
5410-S14-10-12	-12	-10	1 7/16-16 UN	2.15	54.6	1.38	35.0	1.63	41.4	1.38	35.0	7/8-14 UNF
5410-S14-12-12	-12	-12	1 7/16-16 UN	2.15	54.6	1.38	35.0	1.63	41.4	1.38	35.0	1 1/16-12 UN
5410-S14-16-16	-16	-16	1 3/4-16 UN	2.37	60.2	1.75	44.4	2.00	50.8	1.75	44.4	1 5/16-12 UN

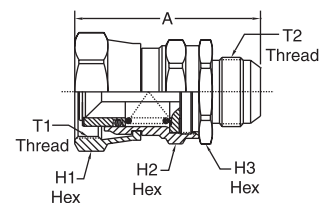

## 5410 Complete Coupling — SAE 37° (JIC)

Part Number Neoprene	Coupling Size	Adapter Size	A	
			Inches	mm
5410-6-4	-4	-6	3.54	89.9
5410-6-8	-8	-6	4.23	107.4
5410-8-8	-8	-8	4.44	112.7
5410-10-12	-12	-10	5.31	134.9
5410-12-12	-12	-12	5.54	140.7
5410-16-16	-16	-16	5.89	149.6

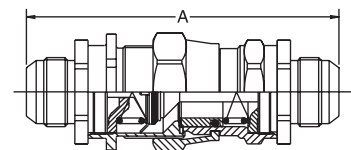

# Components

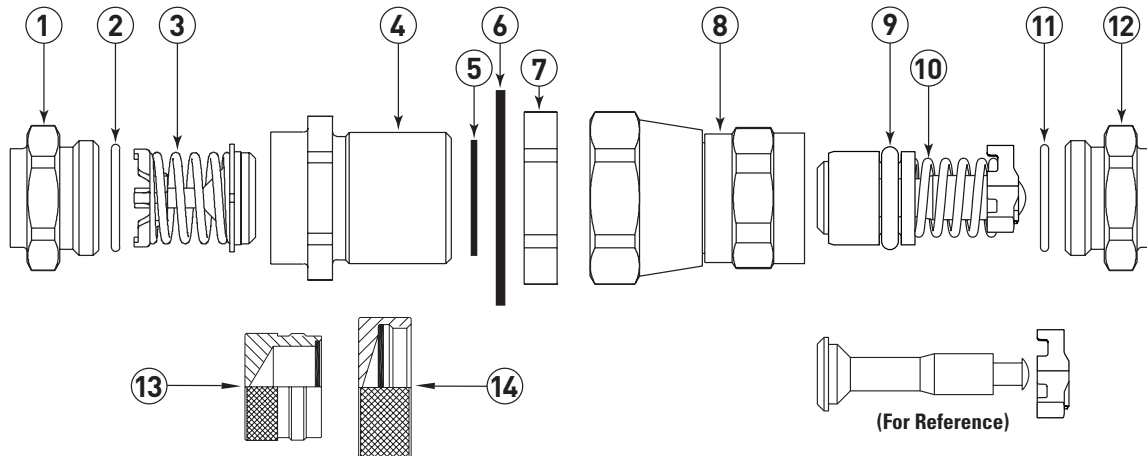

Item No.	Description	Dash Size			
		-4	-8	-12	-16
		Tube O.D. Size – Inches			
		1/4" - 3/8"	1/4" - 5/8"	5/8" - 7/8"	7/8" - 1-3/8"
<b>Typical Male Half</b>					
1	Tubing Adapter (Brass)	202208-*-4B	202208-*-8B	202208-*-12B	202208-*-16B
2	O-Ring	22546-12	RA0486-17	22546-23	22546-28
3	Poppet Valve Assembly	5400-S20-4	5400-S20-8	5400-S20-12	5400-S20-16
4	Body	5400-17-4S	5400-17-8-S	5400-17-12S	5400-17-16S
5	Gasket Seal	22008-4	22008-8	22008-12	22008-16
6	Lock Washer	5400-54-4S	5400-54-8S	5400-54-12S	5400-54-16S
7	Jam Nut	5400-53-4S	5400-53-8S	5400-53-12S	5400-53-16S
13	Dust Cap (S2 half)	5400-S6-4	5400-S6-8	5400-S6-12	5400-S6-16
<b>Typical Female Half</b>					
8	Union Nut and Body Assembly	5400-S16-4	5400-S16-8	5400-S16-12	5400-S16-16
9	O-Ring	22546-10	22546-112	22546-116	22546-214
10**	Valve and Sleeve Assembly	5400-S19-4	5400-S19-8	5400-S19-12	5400-S19-16
11	O-Ring	22546-12	RA0486-17	22546-23	22546-28
12	Tubing Adapter (Brass)	202208-*-4B	202208-*-8B	202208-*-12B	202208-*-16B
14	Dust plug (S5 half)	5400-S8-4	5400-S8-8	5400-S8-12	5400-S8-16

\* Specify O.D. Tubing size of adapter required in 16th of an inch.  
 Example: -4 coupling with 3/8" O.D. tubing = 6/16 or -6.  
 Part number is then 202208-6-4B.

\*\* Item Number 10 is furnished with the O-ring, Item Number 9. However, Item Number 9 can be purchased separately.

## Maximum Bulkhead Thickness

Coupling Size	Lock Washer Installed		Lock Washer Not Used	
	Inches	mm	Inches	mm
-4	0.21	5.33	0.26	6.60
-8	0.14	3.55	0.20	5.08
-12	0.23	5.84	0.29	7.36
-16	0.10	2.54	0.16	4.06

## Recommended Torque Values

Dash Size	S2 Half to S5 Half	
	ft - lbs	N.m
-4	10 - 12	13.6 - 16.3
-8	35 - 37	47.5 - 50.2
-12	45 - 47	61.0 - 63.7
-16	65 - 67	88.1 - 90.8

## Adapter Torque Value

Dash Size	Adapter Braze (Brass)		Adapter Non-Braze (Steel)	
	ft - lbs	N.m	ft - lbs	N.m
-4	6 - 8	8.1 - 10.8	12 - 15	16.3 - 20.3
-8	15 - 20	20.3 - 27.1	35 - 45	47.5 - 61.0
-12	35 - 40	47.5 - 54.2	45 - 55	61.0 - 74.6
-16	50 - 60	67.8 - 81.3	55 - 65	74.6 - 88.1

## Recommended Jam Nut Torque Values

Dash Size	S2 Half to Bulkhead	
	ft - lbs	N.m
-4	18 - 22	24.4 - 28.9
-8	56 - 60	75.9 - 81.3
-12	71 - 75	96.3 - 101.7
-16	101 - 110.5	136.9 - 142.4



# Assembly Instructions

## Step 1

After tubing or hose has been connected to adapters\*\* (1) and (12), install adapter O-rings (2) and (11)\* on adapters. Be sure O-rings are not twisted.

## Step 2

Generously lubricate adapter O-rings (2) and (11) with the system lubricant to prevent them from scuffing and tearing when coupling body is threaded on adapter.

## Step 3

Adapter to S2 male coupling half connection.

- A. Lubricate poppet face with system lubricant. Insert poppet valve assembly (3) into body (4). Tighten body (4) on adapter (1).
- B. After body and adapter make metal-to-metal contact, torque to the value shown in the "Torque Values" table.

## Step 4

Adapter to S5 female coupling half connection.

- A. Lubricate O-ring (9) liberally with system lubricant. Insert valve and sleeve assembly (10) into body (8). Tighten body (8) on adapter (12).
- B. After body and adapter make metal-to-metal contact, torque to the value shown in the "Torque Values" table.

## Step 5

Coupling connection.

- A. Generously lubricate the gasket seal (5) on the 5400-S2 male coupling half with the system lubricant.
- B. Thread the union nut (8) onto the S2 male coupling half. Tighten union nut to torque values shown in the "Torque Values" table.

**IMPORTANT - DO NOT** rotate the S5 female coupling half body during connection.

- C. After the coupling halves are seated, keep the bodies of the S2 male coupling half (4)

and that of the S5 female coupling half (8) from rotating and tighten the union nut to the torque values shown in the "Torque Values" table.

**IMPORTANT - DO NOT** rotate the S2 or S5 coupling half body during connection.

## Bulkhead Mounting — S2 Half

Install lock washer (6) on S2 half, insert S2 male coupling half through bulkhead, and tighten jam-nut (7) so that lock-washer teeth are fully compressed.

**Note:** Lock washer (6) must be between hex of S2 male half and bulkhead.

**IMPORTANT** - Generous lubrication is required for all gaskets and O-rings. Lubrication should match system oil and be compatible with refrigerant system.

\* Specify O.D. Tubing size of adapter required in 16th of an inch.

Example: -4 coupling with 3/8" O.D. tubing = 6/16 or -6. Part number is then 202208-6-4B.

\*\* Contact Parker Sales for alternative adapter sizes or connections.

# Accessories

## Jam Nut

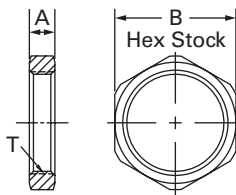

Coupling Size	Jam Nut		
	A	B	T Thread
-4	0.25	3/4	5/8-18 UNF-2B
-8	0.25	1 3/16	1-20 UNEF-2B
-12	0.31	1 9/16	1 7/16-16 UN-2B
-16	0.31	2	1 3/4-16 UN-2B

## Lock Washer

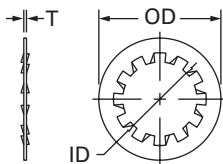

Coupling Size	Lock Washer		
	T	ID	OD
-4	0.045	0.645	1.052
-8	0.063	1.020	1.625
-12	0.055	1.520	2.500
-16	0.055	1.770	2.625

## Adapter — Braze

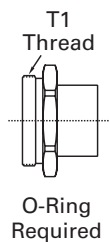

Coupling Size	Part Numbers		Thread Size T1	Tube O.D. Size - Inches
	O-Ring	Brass		
-4	22546-12	202208-4-4B	1/2-20 UNF	1/4
-4	22546-12	202208-5-4B	1/2-20 UNF	5/16
-4	22546-12	202208-6-4B	1/2-20 UNF	3/8
-8	RA0486-17	202208-6-8B	7/8-20 UNEF	3/8
-8	RA0486-17	202208-8-8B	7/8-20 UNEF	1/2
-12	22546-23	202208-10-12B	1 1/4-18 UNEF	5/8
-12	22546-23	202208-12-12B	1 1/4-18 UNEF	3/4
-12	22546-23	202208-14-12B	1 1/4-18 UNEF	7/8
-16	RA0486-28	202208-14-16B	1 19/32-20 UNS	7/8
-16	22546-28	202208-16-16B	1 19/32-20 UNS	1
-16	22546-28	202208-18-16B	1 19/32-20 UNS	1 1/8
-16	22546-28	202208-22-16B	1 19/32-20 UNS	1 3/8

## Adapter SAE 37° (JIC)

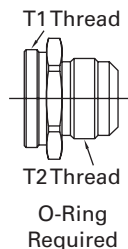

Coupling Size	Part Numbers			Thread Size T1	Thread Size T2	Tube O.D. Size Inches
	O-Ring	Brass	Steel			
-4	22546-12	202220-6-4B	202220-6-4S	1/2-20 UNF	9/16-18 UNF	3/8
-8	RA0486-17		202220-6-8S	7/8-20 UNEF	9/16-18 UNF	3/8
-8	RA0486-17		202220-8-8S	7/8-20 UNEF	3/4-16 UNF	1/2
-12	22546-23		202220-10-12S	1 1/4-18 UNEF	7/8-14 UNF	5/8
-12	22546-23		202220-12-12S	1 1/4-18 UNEF	1 1/16-12 UN	3/4
-16	22546-28		202220-16-16S	1 19/32-20 UNS	1 5/16-12 UN	1

# 5500 Series Self-Sealing Brass Coupling

Parker's 5500 self-sealing brass couplings allow for pre-charging of AC and heat pump systems. The couplings provide for easy maintenance and installation on refrigeration and air conditioning systems. Applications can also include marine refrigeration and air conditioning systems, split refrigeration, and portable cooling solutions.

## Application

- Portable split-system air conditioners
- Split refrigeration systems
- Marine refrigeration systems
- Refrigerated dry cleaning systems
- Beverage systems
- Compatible with most refrigerants including R-410A



## Base Product Part Number

- **5502** Male coupling half
- **5505** Female coupling half

## Features and Benefits

- Self-sealing upon disconnection maintains minimum air inclusion and fluid loss.

- Brass coupling provides corrosion resistance.
- Final metal-to-metal seal prevents refrigerant loss.
- Copper-sweat connections provide basic ends for brazing and eliminate the need for flux, simplifying the installation process.
- Panel mounting options are available for the unique needs of a unit.
- RoHS Compliant

## Agency Approvals

UL listed; File No: SA7511

**Efficient**  
Flow/low pressure drop design helps improve equipment efficiencies.

**Easy to Connect/ Disconnect**  
Thread-together design allows easy connection and disconnection while under system pressure.

**Simplified Installation**  
Copper sweat connections simplify the factory installation process (eliminating the need for flux and flux residue clean up), saving you time and money.

**Corrosion Resistant**  
Brass body and copper connections make corrosion-related problems almost non-existent.

**Low Air Inclusion and Refrigerant Loss**

**Superior Sealing**  
Unique self-sealing valving prevents refrigerant loss when disconnected. Metal-to-metal final seal virtually eliminates refrigerant loss when connected.

**Reliable**  
Stringent design standards, backed by years of experience, a wide range of existing coupling applications, and extensive testing under extreme operating conditions, provide you with the assurance that the product will perform as specified.

# How It Operates

## Disconnected

When disconnected, spring-loaded valve assemblies in the male and female coupling halves are sealed to prevent refrigerant loss and the inclusion of air or foreign materials. A spring in the male coupling half presses the bonded poppet against sealing surface “A” of the coupling body. Likewise, a spring in the female coupling half presses the sleeve against sealing surface “B” of the stem valve head. An O-ring on the female sleeve prevents leakage between the sleeve and coupling body.

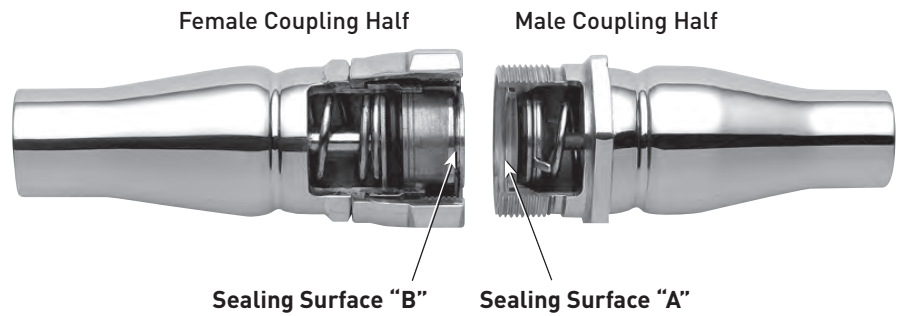

## Partially Connected

As the two coupling halves are threaded together, sealing surface “C” of the male coupling body contacts the bonded seal of the female coupling’s sleeve assembly.

At the same time, the stem valve head in the female coupling assembly contacts the male coupling’s bonded poppet, forcing air out of the coupling. During this stage, both coupling halves are sealed, preventing leakage of refrigerant.

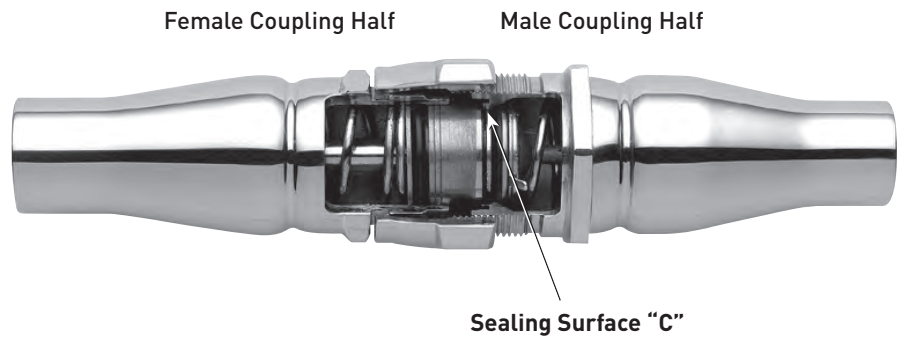

## Fully Connected

Continued tightening of the union nut (female coupling) draws the couplings together, and opens the fluid passage by forcing the male coupling’s poppet assembly and the female coupling’s sleeve assembly open. When fully coupled a metal ring located in the front of the male coupling, forms a leak-free metal to metal seal between the two coupling halves.

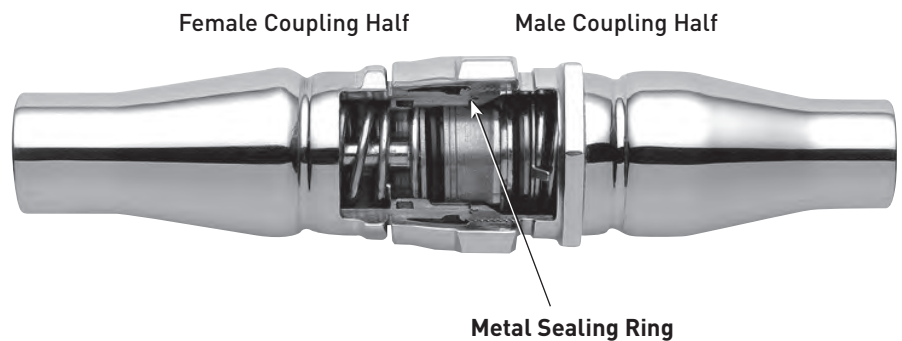

# Specifications

PRODUCT	5500 SERIES SELF-SEALING BRASS COUPLINGS
Operating Temperature Range	-40°F to 250°F (-40°C to +121°C)
Operating Pressure Range, Connected Male & Female Coupling -06, -08, -12 & -16 Body Sizes	Vacuum to 750 psi (52 bar)
Operating Pressure Range, Disconnected Male Coupling Half -06, -08, -12 & -16 Body Sizes Female Coupling Half -06 & -08 Body Sizes -12 Body Size -16 Body Size	Vacuum to 750 psi (52 bar)  Vacuum to 600 psi (41 bar) -6 only Vacuum to 750 psi (52 bar) -8 & -12 Vacuum to 333 psi (23 bar)
Minimum Burst Pressure, Connected Male & Female Coupling -06, -08, -12 & -16 Body Sizes	2,700 psi (186 bar)
Minimum Burst Pressure, Disconnected Male Coupling Half -06, -08, -12 & -16 Body Sizes Female Coupling Half -06 Body Size -08 Body Size -12 Body Size -16 Body Size	2,700 psi (186 bar)  1,800 psi (124 bar) 2,250 psi (155 bar) 2,250 psi (155 bar) 1,000 psi (70 bar)
Maximum Air Inclusion (During Connection) Male & Female Coupling Halves -06 Body Size -08 Body Size -12 Body Size -16 Body Size	0.15 cc per connection 0.10 cc per connection 0.20 cc per connection 0.40 cc per connection
Maximum Fluid Loss (During Disconnection) Male & Female Coupling Halves -06 & -08 Body Sizes -12 Body Size -16 Body Size	0.10 cc per disconnection 0.30 cc per disconnection 0.20 cc per disconnection
MATERIALS	
Coupling Body	Brass Bar per ASTM-B16, Alloy C3600
Connections	Refrigeration Grade Copper, per ASTM-B75, Alloy C12200
Internal Assembly (Female & Male Coupling)	ASTM - B16 Alloy C360 & Zinc Trivalent Chromate Plated Steel
Bonded Poppet (Male Coupling)	Neoprene™
Bonded Sleeve (Female Coupling)	Neoprene™
MATERIAL COMPATIBILITY <sup>+</sup>	
All components, bonded poppet and sleeve, and valve stem O-Ring seal are compatible with these refrigerants and refrigerant oils: R22 & mineral oil, alkylbenzene oil, polyolester oil, & PAG R134a, R404a, R407c, R410a, or R507 & polyolester oil	
Vibration Resistance	Complies with UL 109
External Leak Rate, Connected -06, -08, -12 & -16 Body Sizes	< 0.1 ounce (2.8 g) of R22 refrigerant per year at Operating Pressure Range
External Leak Rate, Disconnected -06, -08, -12 & -16 Body Sizes Without Protective Metal Cap or Plug Installed -08, -12 & -16 Body Sizes With Protective Metal Cap or Plug Installed*	< 0.50 ounce (14.2 g) of R22 refrigerant per year  < 0.25 ounce (7.1 g) of R22 refrigerant per year

\* Protective metal cap/plug not available for -06 coupling body size.

+ Due to the numerous manufacturers of refrigerant oils and continuous changes of additives, compatibility cannot be guaranteed.  
Contact Parker for compatibility of refrigerant oils not listed.

# Flow Data

### Liquid Line Pressure Drop vs. Mass Flow Refrigerant R22 and R410A

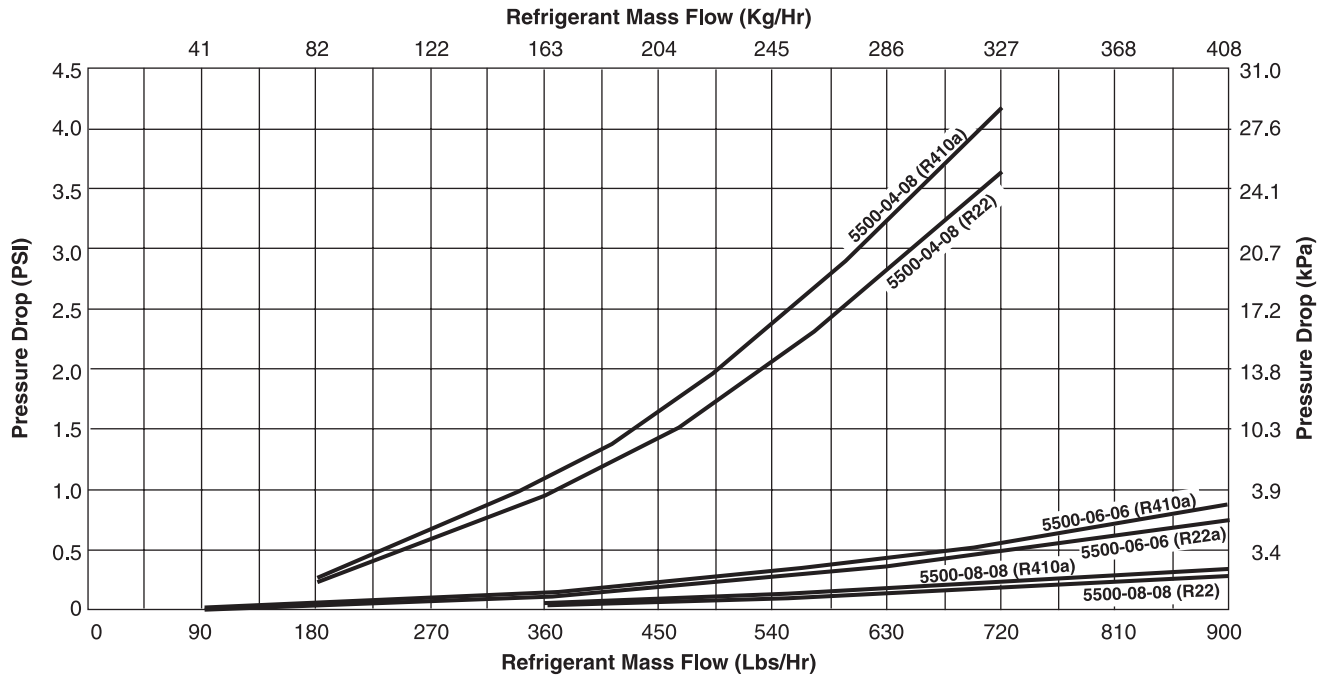

5500-04-08 — 1/2" coupling body (-08) with 1/4" (-04) copper connection, R22  
 5500-06-06 — 3/8" coupling body (-06) with 3/8" (-06) copper connection, R22  
 5500-08-08 — 1/2" coupling body (-08) with 1/2" (-08) copper connection, R22

5500-04-08 — 1/2" coupling body (-08) with 1/4" (-04) copper connection, R410a  
 5500-06-06 — 3/8" coupling body (-06) with 3/8" (-06) copper connection, R410a  
 5500-08-08 — 1/2" coupling body (-08) with 1/2" (-08) copper connection, R410a

### Suction Line Pressure Drop vs. Mass Flow Refrigerant R22 and R410A

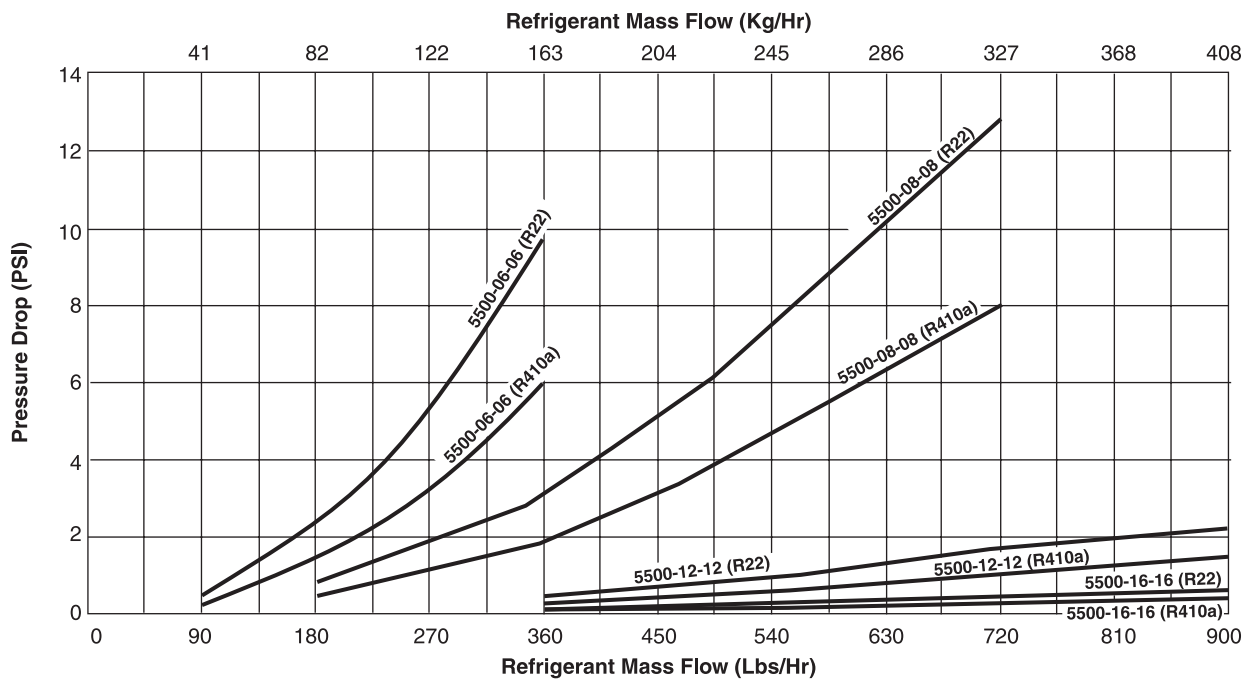

5500-06-06 — 3/8" coupling body (-06) with 3/8" (-06) copper connection, R22  
 5500-08-08 — 1/2" coupling body (-08) with 1/2" (-08) copper connection, R22  
 5500-12-12 — 3/4" coupling body (-12) with 3/4" (-12) copper connection, R22  
 5500-16-16 — 1" coupling body (-16) with 1" (16) copper connection, R22

5500-06-06 — 3/8" coupling body (-06) with 3/8" (-06) copper connection, R410a  
 5500-08-08 — 1/2" coupling body (-08) with 1/2" (-08) copper connection, R410a  
 5500-12-12 — 3/4" coupling body (-12) with 3/4" (-12) copper connection, R410a  
 5500-16-16 — 1" coupling body (-16) with 1" (16) copper connection, R410a

# Coupling Assembly

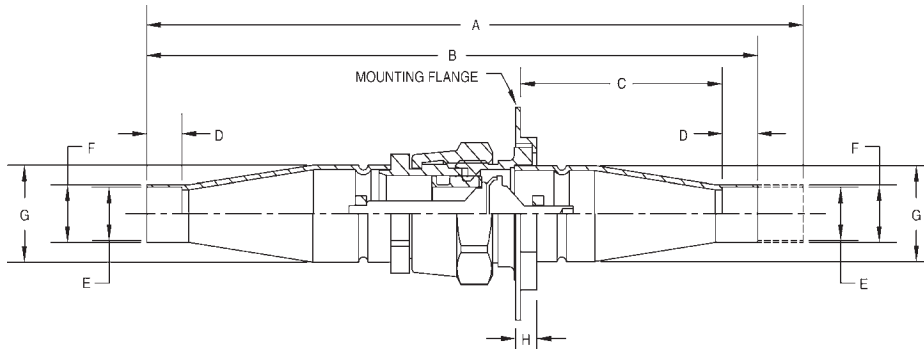

Copper Connection		Coupling Body	Kit Part Number	Dimensions – Inches (mm)							
Inch (Dash Size*)	mm	Inch (Dash Size)	5500 Copper Coupling Body Size	Overall Disconnected Length	Overall Connected Length	Flange to Tube End	Connection Depth	Connection I.D.	Connection O.D.	Copper O.D.	Mounting Flange (Width)
				A	B	C	D	E	F	G	H
1/4 ODF (-04)	6.4 ODF	3/8 (-06)	N/A	5.06 (128.5)	4.77 (121.2)	N/A	0.32 (8.1)	0.25 (6.4)	0.34 (8.6)	0.71 (18.0)	N/A
3/8 ODF (-06)	9.5 ODF	3/8 (-06)	N/A	5.06 (128.5)	4.77 (121.2)	N/A	0.32 (8.1)	0.38 (9.7)	0.46 (11.7)	0.71 (18.0)	N/A
1/4 ODF (-04)	6.4 ODF	1/2 (-08)	5500-04-08	6.95 (176.5)	6.56 (166.6)	2.64 (67.1)	0.31 (7.9)	0.25 (6.4)	0.38 (9.7)	0.92 (23.4)	0.23 (5.8)
3/8 ODF (-06)	9.5 ODF	1/2 (-08)	5500-06-08	6.90 (174.2)	6.51 (165.4)	2.62 (66.5)	0.31 (7.9)	0.38 (9.7)	0.47 (12.0)	0.92 (23.4)	0.23 (5.8)
1/2 ODF (-08)	12.7 ODF	1/2 (-08)	5500-08-08	6.86 (172.2)	6.47 (164.3)	2.58 (65.5)	0.38 (9.7)	0.50 (12.7)	0.59 (14.9)	0.92 (23.4)	0.23 (5.8)
5/8 ODF (-10)	15.9 ODF	1/2 (-08)	5500-10-08	6.78 (172.2)	6.39 (162.3)	2.56 (65.0)	0.38 (9.7)	0.63 (16.0)	0.71 (17.9)	0.92 (23.4)	0.23 (5.8)
5/8 ODF (-10)	15.9 ODF	3/4 (-12)	5500-10-12	7.79 (197.9)	7.24 (183.9)	2.71 (68.8)	0.50 (12.7)	0.63 (16.0)	0.75 (19.1)	1.32 (33.5)	0.23 (5.8)
3/4 ODF (-12)	19.1 ODF	3/4 (-12)	5500-12-12	7.85 (199.4)	7.30 (185.4)	2.67 (67.8)	0.62 (15.7)	0.75 (19.1)	0.86 (21.7)	1.32 (33.5)	0.23 (5.8)
7/8 ODF (-14)	22.2 ODF	3/4 (-12)	5500-14-12	7.85 (199.4)	7.30 (185.4)	2.67 (67.8)	0.75 (19.1)	0.88 (22.4)	0.97 (24.6)	1.32 (33.5)	0.23 (5.8)
7/8 ODF (-14)	22.2 ODF	1 (-16)	5500-14-16	9.33 (237.0)	8.73 (221.7)	3.34 (84.8)	0.75 (19.1)	0.88 (22.4)	1.02 (25.8)	1.68 (42.7)	0.23 (5.8)
1 ODF (-16)	25.4 ODF	1 (-16)	5500-16-16	9.46 (240.3)	8.86 (225.0)	3.42 (86.9)	0.88 (22.4)	1.00 (25.4)	1.12 (28.4)	1.68 (42.7)	0.23 (5.8)
1-1/8 ODF (-18)	28.6 ODF	1 (-16)	5500-18-16	9.45 (240.0)	8.85 (224.8)	3.42 (86.9)	0.88 (22.4)	1.13 (28.7)	1.24 (31.4)	1.68 (42.7)	0.23 (5.8)

\* Dash size = copper connection size x 16

# Female Coupling Half

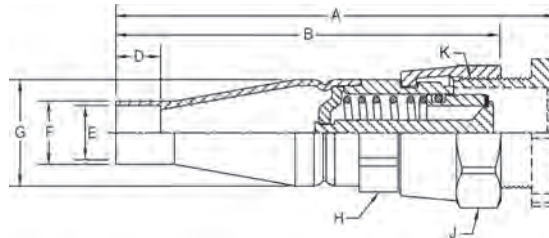

Copper Connection		Coupling Body	Part Number		Dimensions – Inches (mm)								
Inch (Dash Size*)	mm	Inch (Dash Size)	Less Plug	With Plug**	Coupling Length		Connection			Copper	Coupling Body	Union Nut Hex <sup>+</sup>	Thread Size
					With Plug		Depth	I.D.	O.D.	O.D.	Hex <sup>+</sup>		
					A	B	D	E	F	G	H		
1/4 ODF (-04)	6.4 ODF	3/8 (-06)	N/A	5505-04B-06	3.14 (79.8)	2.72 (69.1)	0.32 (8.1)	0.25 (6.4)	0.34 (8.6)	0.71 (18.0)	0.75 (19.1)	0.94 (23.9)	M20-1.5
3/8 ODF (-06)	9.5 ODF	3/8 (-06)	N/A	5505-06B-06	3.14 (79.8)	2.72 (69.1)	0.32 (8.1)	0.38 (9.7)	0.46 (11.7)	0.71 (18.0)	0.75 (19.1)	0.94 (23.9)	M20-1.5
1/4 ODF (-04)	6.4 ODF	1/2 (-08)	N/A	5505-04B-08	3.80 (96.5)	3.60 (91.4)	0.31 (7.9)	0.25 (6.4)	0.38 (9.7)	0.92 (23.4)	1.00 (25.4)	1.19 (30.2)	1-20 UNEF
1/4 ODF (-04)	6.4 ODF	1/2 (-08)	N/A	5505-04S-08	3.95 (100.3)	3.60 (91.4)	0.31 (7.9)	0.25 (6.4)	0.38 (9.7)	0.92 (23.4)	1.00 (25.4)	1.19 (30.2)	1-20 UNEF
3/8 ODF (-06)	9.5 ODF	1/2 (-08)	N/A	5505-06B-08	3.85 (97.8)	3.66 (93.0)	0.31 (7.9)	0.38 (9.7)	0.47 (12.0)	0.92 (23.4)	1.00 (25.4)	1.19 (30.2)	1-20 UNEF
3/8 ODF (-06)	9.5 ODF	1/2 (-08)	N/A	5505-06S-08	4.01 (101.9)	3.66 (93.0)	0.31 (7.9)	0.38 (9.7)	0.47 (12.0)	0.92 (23.4)	1.00 (25.4)	1.19 (30.2)	1-20 UNEF
1/2 ODF (-08)	12.7 ODF	1/2 (-08)	N/A	5505-08B-08	3.85 (97.8)	3.66 (93.0)	0.38 (9.7)	0.50 (12.7)	0.59 (14.9)	0.92 (23.4)	1.00 (25.4)	1.19 (30.2)	1-20 UNEF
1/2 ODF (-08)	12.7 ODF	1/2 (-08)	N/A	5505-08S-08	4.01 (101.9)	3.66 (93.0)	0.38 (9.7)	0.50 (12.7)	0.59 (14.9)	0.92 (23.4)	1.00 (25.4)	1.19 (30.2)	1-20 UNEF
5/8 ODF (-10)	15.9 ODF	1/2 (-08)	N/A	5505-10B-08	3.88 (98.6)	3.69 (93.7)	0.50 (12.7)	0.63 (16.0)	0.71 (17.9)	0.92 (23.4)	1.00 (25.4)	1.19 (30.2)	1-20 UNEF
5/8 ODF (-10)	15.9 ODF	1/2 (-08)	N/A	5505-10S-08	4.04 (102.6)	3.69 (93.7)	0.50 (12.7)	0.63 (16.0)	0.71 (17.9)	0.92 (23.4)	1.00 (25.4)	1.19 (30.2)	1-20 UNEF
5/8 ODF (-10)	15.9 ODF	3/4 (-12)	5505-10-12	5505-10S-12	4.64 (117.9)	4.09 (103.9)	0.50 (12.7)	0.63 (16.0)	0.75 (19.1)	1.32 (33.5)	1.38 (35.1)	1.62 (30.2)	1 7/16-16 UN
3/4 ODF (-12)	19.1 ODF	3/4 (-12)	5505-12-12	5505-12S-12	4.77 (121.2)	4.19 (106.4)	0.62 (15.7)	0.75 (19.1)	0.86 (21.7)	1.32 (33.5)	1.38 (35.1)	1.62 (41.4)	1 7/16-16 UN
7/8 ODF (-14)	22.2 ODF	3/4 (-12)	5505-14-12	5505-14S-12	4.77 (121.2)	4.19 (106.4)	0.75 (19.1)	0.88 (22.4)	0.97 (24.6)	1.32 (33.5)	1.38 (35.1)	1.62 (41.4)	1 7/16-16 UN
7/8 ODF (-14)	22.2 ODF	1 (-16)	5505-14-16	5505-14S-16	5.48 (139.2)	4.96 (126.0)	0.75 (19.1)	0.88 (22.4)	1.02 (25.8)	1.68 (42.7)	1.69 (42.9)	2.00 (50.8)	1 3/4-16 UN
1 ODF (-16)	25.4 ODF	1 (-16)	5505-16-16	5505-16S-16	5.62 (142.7)	5.01 (127.3)	0.88 (22.4)	1.00 (25.4)	1.12 (28.4)	1.68 (42.7)	1.69 (42.9)	2.00 (50.8)	1 3/4-16 UN
1-1/8 ODF (-18)	28.6 ODF	1 (-16)	5505-18-16	5505-18S-16	5.52 (140.2)	5.00 (127.0)	0.88 (22.4)	1.13 (28.7)	1.24 (31.4)	1.68 (42.7)	1.69 (42.9)	2.00 (50.8)	1 3/4-16 UN

\* Dash size = copper connection size x 16

\*\* "B" in the part number denotes a plastic plug. "S" in the part number denotes a steel plug.

+ Dimension is across hex flats.

# Male Coupling Half

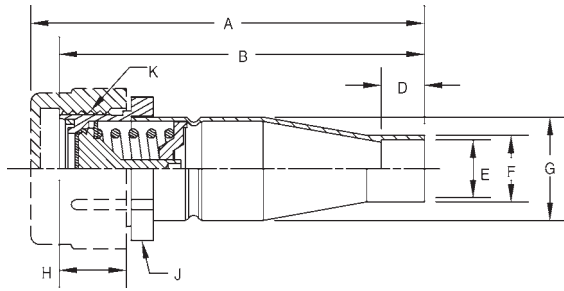

Copper Connection		Coupling Body	Part Number**		Dimensions – Inches (mm)								
					Coupling Length		Connection			Copper	Coupling Body		Thread Size
Inch (Dash Size*)	mm	Inch (Dash Size)	Less Cap	With Cap**	With Cap	Depth	I.D.	O.D.	O.D.	Thread Length	Hex Diameter <sup>+</sup>	K	
					A	B	D	E	F	G	H		J
1/4 ODF (-04)	6.4 ODF	3/8 (-06)	N/A	5502-04B-06	2.58 (65.5)	2.40 (61.0)	0.32 (8.1)	0.25 (6.4)	0.34 (8.6)	0.71 (18.0)	0.49 (12.4)	0.83 (21.1)	M20-1.5
3/8 ODF (-06)	9.5 ODF	3/8 (-06)	N/A	5502-06B-06	2.58 (65.5)	2.40 (61.0)	0.32 (8.1)	0.38 (9.7)	0.46 (11.7)	0.71 (18.0)	0.49 (12.4)	0.83 (21.1)	M20-1.5
1/4 ODF (-04)	6.4 ODF	1/2 (-08)	N/A	5502-04B-08	3.23 (82.0)	3.18 (80.8)	0.31 (7.9)	0.25 (6.4)	0.38 (9.7)	0.92 (23.4)	0.62 (15.7)	1.13 (28.7)	1-20 UNEF
1/4 ODF (-04)	6.4 ODF	1/2 (-08)	N/A	5502-04S-08	3.39 (86.1)	3.18 (80.8)	0.31 (7.9)	0.25 (6.4)	0.38 (9.7)	0.92 (23.4)	0.62 (15.7)	1.13 (28.7)	1-20 UNEF
3/8 ODF (-06)	9.5 ODF	1/2 (-08)	N/A	5502-06B-08	3.25 (82.5)	3.20 (81.3)	0.31 (7.9)	0.38 (9.7)	0.47 (12.0)	0.92 (23.4)	0.62 (15.7)	1.13 (28.7)	1-20 UNEF
3/8 ODF (-06)	9.5 ODF	1/2 (-08)	N/A	5502-06S-08	3.41 (86.6)	3.20 (81.3)	0.31 (7.9)	0.38 (9.7)	0.47 (12.0)	0.92 (23.4)	0.62 (15.7)	1.13 (28.7)	1-20 UNEF
1/2 ODF (-08)	12.7 ODF	1/2 (-08)	N/A	5502-08B-08	3.28 (83.3)	3.23 (82.0)	0.38 (9.7)	0.50 (12.7)	0.59 (14.9)	0.92 (23.4)	0.62 (15.7)	1.13 (28.7)	1-20 UNEF
1/2 ODF (-08)	12.7 ODF	1/2 (-08)	N/A	5502-08S-08	3.45 (87.6)	3.23 (82.8)	0.38 (9.7)	0.50 (12.7)	0.59 (14.9)	0.92 (23.4)	0.62 (15.7)	1.13 (28.7)	1-20 UNEF
5/8 ODF (-10)	15.9 ODF	1/2 (-08)	N/A	5502-10B-08	3.31 (84.1)	3.26 (82.8)	0.50 (12.7)	0.63 (16.0)	0.71 (17.9)	0.92 (23.4)	0.62 (15.7)	1.13 (28.7)	1-20 UNEF
5/8 ODF (-10)	15.9 ODF	1/2 (-08)	N/A	5502-10S-08	3.99 (101.3)	3.26 (82.8)	0.50 (12.7)	0.63 (16.0)	0.71 (17.9)	0.92 (23.4)	0.62 (15.7)	1.13 (28.7)	1-20 UNEF
5/8 ODF (-10)	15.9 ODF	3/4 (-12)	5502-10-12	5502-10S-12	3.91 (99.3)	3.70 (93.9)	0.50 (12.7)	0.63 (16.0)	0.75 (19.1)	1.32 (33.5)	0.99 (25.1)	1.63 (41.4)	1 7/16-16 UN
3/4 ODF (-12)	19.1 ODF	3/4 (-12)	5502-12-12	5502-12S-12	3.96 (100.6)	3.75 (95.3)	0.62 (15.7)	0.75 (19.1)	0.86 (21.7)	1.32 (33.5)	0.99 (25.1)	1.63 (41.4)	1 7/16-16 UN
7/8 ODF (-14)	22.2 ODF	3/4 (-12)	5502-14-12	5502-14S-12	3.96 (100.6)	3.75 (95.3)	0.75 (19.1)	0.88 (22.4)	0.97 (24.6)	1.32 (33.5)	0.99 (25.1)	1.63 (41.4)	1 7/16-16 UN
7/8 ODF (-14)	22.2 ODF	1 (-16)	5502-14-16	5502-14S-16	4.68 (118.9)	4.37 (111.0)	0.75 (19.1)	0.88 (22.4)	1.02 (25.8)	1.68 (42.7)	1.03 (26.2)	1.88 (47.8)	1 3/4-16 UN
1 ODF (-16)	25.4 ODF	1 (-16)	5502-16-16	5502-16S-16	4.76 (120.9)	4.45 (113.0)	0.88 (22.4)	1.00 (25.4)	1.12 (28.4)	1.68 (42.7)	1.03 (26.2)	1.88 (47.8)	1 3/4-16 UN
1-1/8 ODF (-18)	28.6 ODF	1 (-16)	5502-18-16	5502-18S-16	4.76 (120.9)	4.45 (113.0)	0.88 (22.4)	1.13 (28.7)	1.24 (31.4)	1.68 (42.7)	1.03 (26.2)	1.88 (47.8)	1 3/4-16 UN

\* Dash size = copper connection size x 16

\*\* "B" in the part number denotes a plastic cap. "S" in the part number denotes a steel cap.

+ Dimension is across hex flats.

## Recommended Torque Values

Dash Size	Male Half to Female Half	
	ft - lbs	N.m
-6	18 - 20	24.4 - 27.1
-8	30 - 35	40.7 - 47.5
-12	45 - 50	61.0 - 67.8
-16	60 - 65	81.3 - 88.1



# Accessories

## Protective Plugs

Coupling Body Size		Part Number	Dimensions – Inches (mm)	
Inch (Dash Size*)	mm		Length	Diameter
			A	B
<b>Plastic</b>				
3/8 (-06)	9.5	5410-06	0.72 (18.3)	1.04 (26.4)
1/2 (-08)	12.7	5410-08	0.04 (9.9)	1.20 (30.5)
<b>Steel</b>				
1/2 (-08)	12.7	5400-S8-08	0.72 (18.3)	1.00 (25.4)
3/4 (-12)	19.1	5400-S8-12	1.13 (28.7)	1.44 (36.6)
1 (-16)	25.4	5400-S8-16	1.25 (31.8)	1.75 (44.5)

\* Dash size = coupling body size x 16

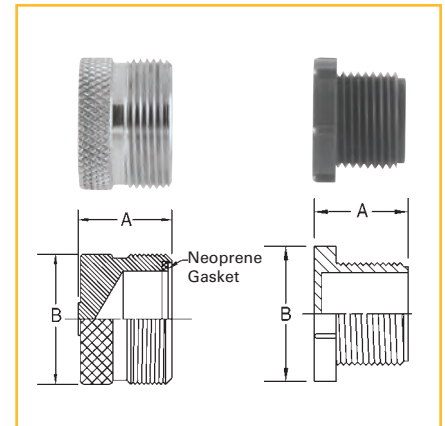

## Protective Caps

Coupling Body Size		Part Number	Dimensions – Inches (mm)	
Inch (Dash Size*)	mm		Length	Diameter
			A	B
<b>Plastic</b>				
3/8 (-06)	9.5	5409-06	0.55 (14.0)	0.93 (23.6)
1/2 (-08)	12.7	Plastic Cap	N/A	N/A
<b>Steel</b>				
1/2 (-08)	12.7	5400-S6-08	0.56 (14.2)	1.13 (28.7)
3/4 (-12)	19.1	5400-S6-12	0.56 (14.2)	1.63 (41.4)
1 (-16)	25.4	5400-S6-16	0.75 (19.1)	2.00 (50.8)

\* Dash size = coupling body size x 16

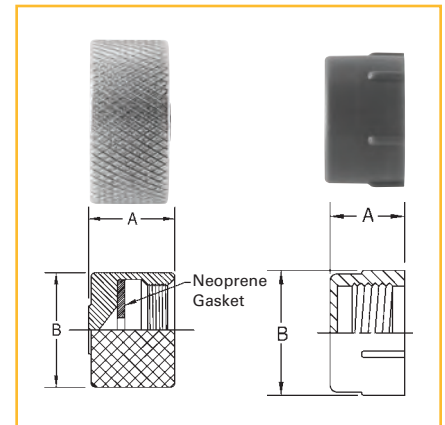

## Mounting Flange (Steel)

Coupling Body Size		Part Number	Dimensions – Inches (mm)		
Inch (Dash Size*)	mm		Hex Diameter A	Bolt Circle Diameter B	Outside Diameter C
3/8 (-06)	9.5	N/A	N/A	N/A	N/A
1/2 (-08)	12.7	150-22-08	1.13 (28.7)	1.69 (42.9)	2.00 (50.8)
3/4 (-12)	19.1	150-22-12	1.63 (41.4)	2.12 (53.9)	2.50 (63.5)
1 (-16)	25.4	150-22-16	1.88 (47.8)	2.38 (60.5)	2.75 (69.9)

\* Dash size = coupling body size x 16

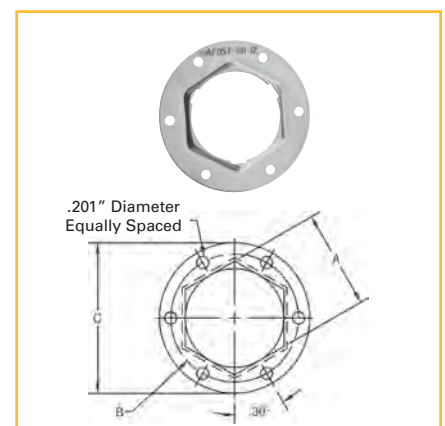

# How to Order

<u><b>5502</b></u> Coupling Type	-	<u><b>04</b></u> Copper Connection Size	-	<u><b>B</b></u> Cap / Plug Requirements	-	<u><b>06</b></u> Coupling Body Size
<b>Product Type</b>		<b>Copper Connection (Denoted xx/16)</b>		<b>Cap For Brass 5502 Threaded Body</b> / <b>Plug For Brass 5505 Hex Nut</b>		<b>Coupling Body Size (Denoted xx/16)</b>
5502 = Male Coupling Half 5505 = Female Coupling Half		-04 = 1/4" -06 = 3/8" -08 = 1/2" -10 = 5/8" -12 = 3/4" -14 = 7/8" -16 = 1" -18 = 1-1/8"		-06 includes plastic cap or plug (no steel option available) -08 can be ordered with plastic or steel cap or plug -12 and -16 can be ordered with or without a steel cap or plug (no plastic option available) B = Includes Plastic Protective Cap or Plug S = Includes Steel Protective Cap or Plug		-06 = 3/8" -08 = 1/2" -12 = 3/4" -16 = 1"

## Bulkhead Mount Installation

Applicable for sizes -08, -12, and -16

### Bulkhead Set-up



### Step 1

Drill holes in bulkhead or panel to accommodate 5502 coupling half and flange mounting screws. Remove dust cap before positioning on bulkhead. Mount male coupling in half by sliding

flange over end of coupling (before brazing tubing) and attaching to bulkhead with self tapping sheet metal screws. Reinstall dust cap before brazing.

### Step 2

Braze tubing ends using running water bath, chill blocks or wet rags on coupling bodies to prevent seal damage.

### Step 3

Remove dust caps and plugs if used, making sure that component synthetic seals are intact.

### Step 4

Wipe off coupling seals and threaded surfaces with a clean cloth to prevent the inclusion of dirt or any foreign material in the system.

### Step 5

LUBRICATE rubber seal in male half with refrigeration oil. Thread coupling halves together by hand to insure proper mating of threads. Use proper size wrench (on coupling body hex and on union nut) and tighten until coupling bodies "bottom" or a definite resistance

is felt. Using a marker or ink pen, mark a line lengthwise from the union nut to the bulkhead. Then tighten an additional 1/8 to 1/4 turn. The misalignment of the line will show the degree of tightening. This final turn is necessary to insure that the knife edge metal seal bites into the brass seat of the coupling halves, forming the leakproof joint. If torque wrench is used, use the torque values listed in the 5500 series torque specifications.

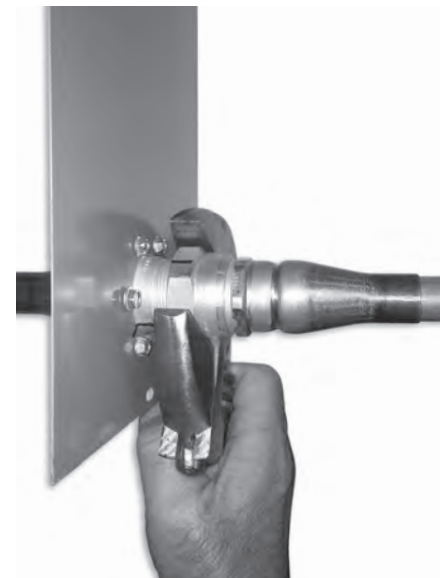

# 5700 Series One-Shot™ Brass Couplings

Parker's 5700 one-shot brass couplings allow for easy installation of pre-charged systems and provide nearly full flow when completely connected. Applications typically include split air conditioning systems, split heat pumps, manufacturing systems, split heat pumps, manufactured homes, and pre-charged line sets.

## Application

- Split air conditioning systems
- Split heat pumps
- Manufactured homes

## Base Product Part Number

- **5780** Female coupling half without charge port
- **5781** Female coupling half with charge port
- **5782** Male coupling half without charge port
- **5783** Male coupling half with charge port

## Features and Benefits

- Single-use coupling contains a diaphragm that is pierced upon connection and folded back into the coupling to provide a high flow path and low pressure drop.
- Final metal-to-metal seal prevents air inclusion.
- Brass coupling provides corrosion resistance.
- Brass sweat connections and panel-mounting options are available for the unique needs of a unit.
- Male/female charge ports can be included for easy system diagnostics.
- Stub kits (FD57) are also available with copper connections.
- Compatible with all refrigerants
- RoHS compliant
- Disconnected operating pressure: vacuum to 700 psi. Connected minimum burst pressure: 2100 psi.

## Agency Approvals

UL listed; File No: SA7511

## Pressure Drop Comparison

The graphs below show significant reduction in pressure drop and associated efficiency gains utilizing Parker 5700 Series Couplings vs. standard base valves.



**Pressure Drop vs. Mass Flow**  
-10 Suction Line, Refrigerant -22

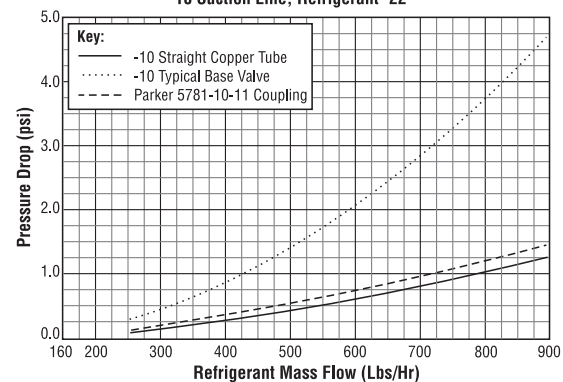

**Pressure Drop vs. Mass Flow**  
-14 Suction Line, Refrigerant -22

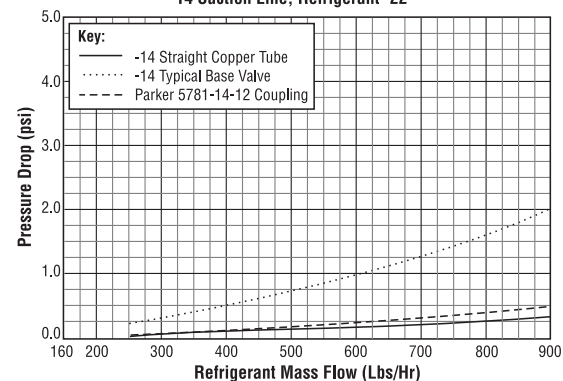

**Pressure Drop vs. Mass Flow**  
-12 Suction Line, Refrigerant -22

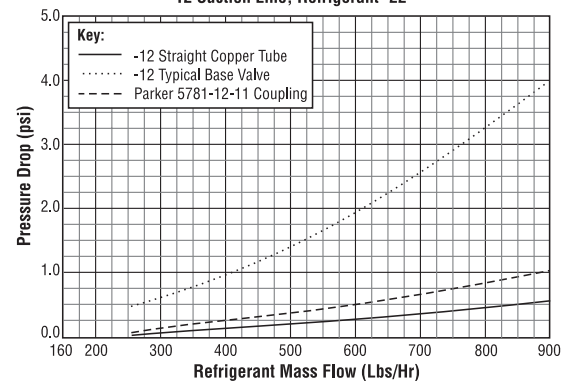

# Technical Information

## Design and Operation

A complete 5780 series coupling consists of the combination of male and female coupling halves. Either coupling half is available with or without a charging port, depending on the particular application.

### Coupling Halves Before Connection

Diaphragms in the coupling halves provide a seal that prevents refrigerant loss before connection. The male half (right unit) contains a cutter blade, the metal refrigerant sealing diaphragm and intermediate synthetic rubber seal which prevent loss of refrigerant while the coupling is being connected. The female half (left unit) contains a metal diaphragm which is a leakproof metal closure.

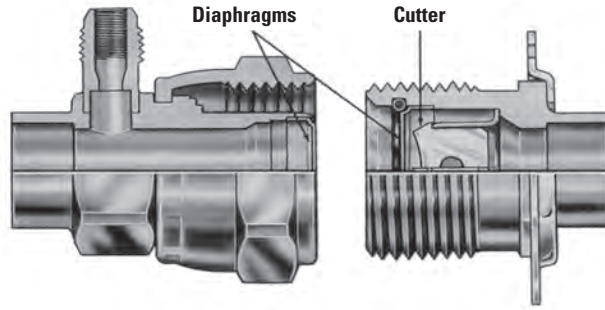

### Coupling Halves Connected

Tightening the union nut draws the coupling halves together, piercing and folding both metal diaphragms back and opening the fluid passage, thereby providing minimal restriction to flow. When fully coupled, a metal seal forms a permanent leakproof joint between the two coupling halves preventing the loss of refrigerant to the atmosphere.

The cutaway views below show male and female coupling halves joined at 20%, 50%, and 100% connection. Note the way the cutter blades pierce the diaphragms and fold them back out of the flow path. Also note the difference in the final sealing area before and after torquing.

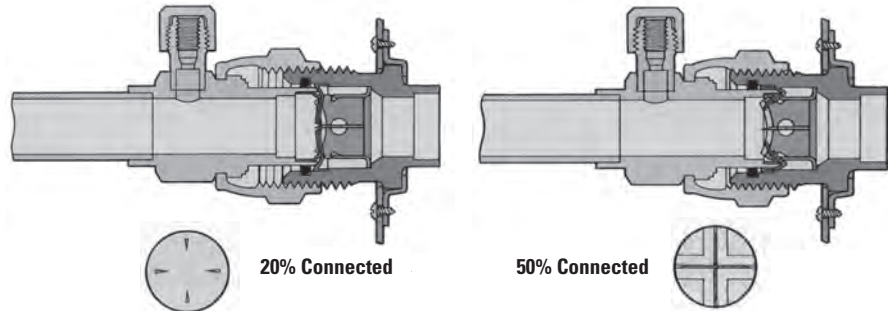
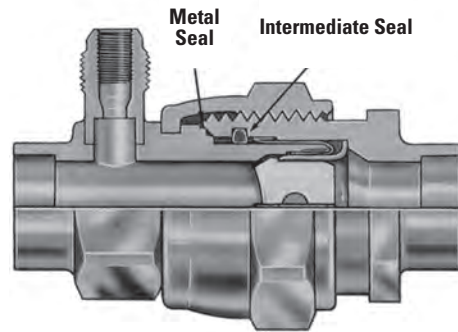

Final sealing area connected prior to torquing

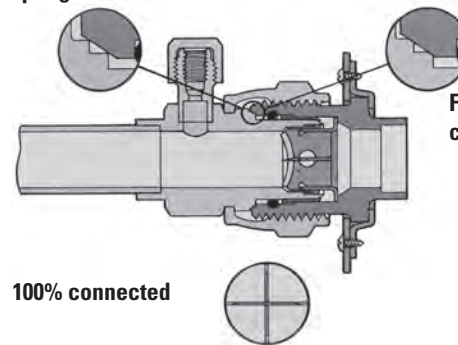

100% connected

Final sealing area connected after torquing

# Dimensions

**5780-Size Female Half without Charge Port**

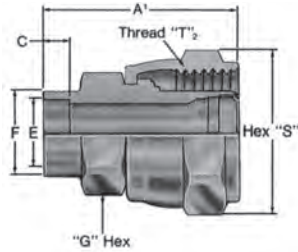

**5781-Size Female Half with Charge Port**

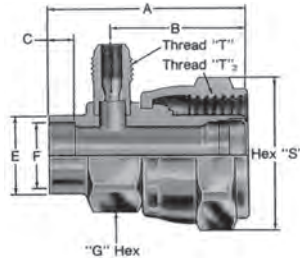

**5782-Size Male Half without Charge Port**

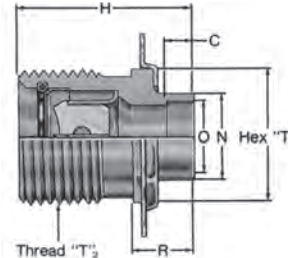

**5783-Size Male Half with Charge Port**

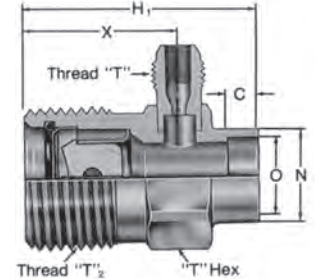

## Dimensional Data – English Units

Basic Cplg. Size	O.D. Tubing Size Inches	Cplg. Dash Size	Thread "T"	Thread "T2"	Dimensions – Inches														
					A	A1	B	C	E	F	G	H	H1	N	O	R	S	T	X
-6	1/4	-4-6	7/16"-20	5/8"-18	1.55	1.30	1.06	0.19	0.25	0.38	0.62	1.21	1.46	0.38	0.25	0.50	0.81	0.75	0.98
-6	5/16	-5-6	7/16"-20	5/8"-18	1.55	1.30	1.06	0.19	0.32	0.44	0.62	1.21	1.46	0.44	0.32	0.50	0.81	0.75	0.98
-6	3/8	-6-6	7/16"-20	5/8"-18	1.55	1.30	1.06	0.19	0.38	0.50	0.62	1.21	1.51	0.50	0.38	0.50	0.81	0.75	0.98
-10	1/2	-8-10	7/16"-20	1-1/16"-12	1.81	1.56	1.24	0.25	0.50	0.62	1.00	1.37	1.66	0.62	0.50	0.52	1.31	1.06	1.10
-10	5/8	-10-10	7/16"-20	1-1/16"-12	1.86	1.61	1.24	0.25	0.62	0.75	1.00	1.43	-	0.75	0.62	0.56	1.31	1.06	-
-10	3/4	-12-10	7/16"-20	1-1/16"-12	1.92	1.67	1.24	0.25	0.75	0.91	1.00	1.52	1.66	0.91	0.75	0.65	1.31	1.06	1.10
-11	1/2	-8-11	7/16"-20	1-1/8"-12	1.85	1.60	1.28	0.25	0.50	0.62	1.00	1.48	1.78	0.62	0.50	0.50	1.31	1.12	1.21
-11	5/8	-10-11	7/16"-20	1-1/8"-12	1.90	1.65	1.28	0.25	0.62	0.75	1.00	1.54	1.84	0.75	0.62	0.56	1.31	1.12	1.22
-11	3/4	-12-11	7/16"-20	1-1/8"-12	1.96	1.71	1.28	0.25	0.75	0.91	1.00	1.63	1.84	0.91	0.75	0.65	1.31	1.12	1.22
-11	7/8	-14-11	7/16"-20	1-1/8"-12	2.06	1.81	1.28	0.31	0.88	0.98	1.00	1.70	1.92	1.03	0.88	0.72	1.31	1.12	1.22
-12	3/4	-12-12	7/16"-20	1-7/16"-16	2.26	2.01	1.60	0.25	0.75	0.91	1.38	1.78	-	0.91	0.75	0.63	1.69	1.44	-
-12	7/8	-14-12	7/16"-20	1-7/16"-16	2.36	2.11	1.60	0.31	0.88	1.03	1.38	1.87	-	1.03	0.88	0.72	1.69	1.44	-
-12	1-1/8	-18-12	7/16"-20	1-7/16"-16	2.43	2.18	1.60	0.31	1.12	1.28	1.38	1.98	-	1.28	1.12	0.84	1.69	1.44	-

## Dimensional Data – Metric Units

Basic Cplg. Size	O.D. Tubing Size Inches	Cplg. Dash Size	Thread "T"	Thread "T2"	Dimensions – mm														
					A	A1	B	C	E	F	G	H	H1	N	O	R	S	T	X
-6	1/4	-4-6	7/16"-20	5/8"-18	39.37	33.02	26.92	4.83	6.35	9.65	15.75	30.73	37.08	9.65	6.35	12.70	20.57	19.05	24.89
-6	5/16	-5-6	7/16"-20	5/8"-18	39.37	33.02	26.92	4.83	8.13	11.18	15.75	30.73	37.08	11.18	8.13	12.70	20.57	19.05	24.89
-6	3/8	-6-6	7/16"-20	5/8"-18	39.37	33.02	26.92	4.83	9.65	12.70	15.75	30.73	38.35	12.70	9.65	12.70	20.57	19.05	24.89
-10	1/2	-8-10	7/16"-20	1-1/16"-12	45.97	39.62	31.50	6.35	12.70	15.75	25.40	34.80	42.16	15.75	12.70	13.21	33.27	26.92	27.94
-10	5/8	-10-10	7/16"-20	1-1/16"-12	47.24	40.89	31.50	6.35	15.75	19.05	25.40	36.32	-	19.05	15.75	14.22	33.27	26.92	-
-10	3/4	-12-10	7/16"-20	1-1/16"-12	48.77	42.42	31.50	6.35	19.05	23.11	25.40	38.61	42.16	23.11	19.05	16.51	33.27	26.92	27.94
-11	1/2	-8-11	7/16"-20	1-1/8"-12	46.99	40.64	32.51	6.35	12.70	15.75	25.40	37.59	45.21	15.75	12.70	12.70	33.27	28.45	30.73
-11	5/8	-10-11	7/16"-20	1-1/8"-12	48.26	41.91	32.51	6.35	15.75	19.05	25.40	39.12	46.74	19.05	15.75	14.22	33.27	28.45	30.99
-11	3/4	-12-11	7/16"-20	1-1/8"-12	49.78	43.43	32.51	6.35	19.05	23.11	25.40	41.40	46.74	23.11	19.05	16.51	33.27	28.45	30.99
-11	7/8	-14-11	7/16"-20	1-1/8"-12	52.32	45.97	32.51	7.87	22.35	24.89	25.40	43.18	48.77	26.16	22.35	18.29	33.27	28.45	30.99
-12	3/4	-12-12	7/16"-20	1-7/16"-16	57.40	51.05	40.64	6.35	19.05	23.11	35.05	45.21	-	23.11	19.05	16.00	42.93	36.58	-
-12	7/8	-14-12	7/16"-20	1-7/16"-16	59.94	53.59	40.64	7.87	22.35	26.16	35.05	47.50	-	26.16	22.35	18.29	42.93	36.58	-
-12	1-1/8	-18-12	7/16"-20	1-7/16"-16	61.72	55.37	40.64	7.87	28.45	32.51	35.05	50.29	-	32.51	28.45	21.34	42.93	36.58	-

# Factory Brazing Instructions

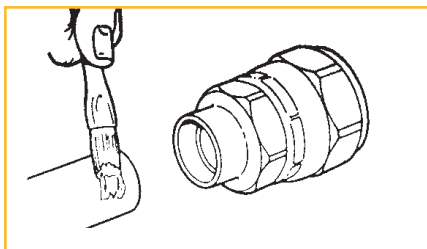

## Step 1

Sparingly apply paste flux to the copper tube.

**Note:** Liquid flux or excessive flux can run inside the coupling and cause corrosion.



## Step 2

Immerse the coupling diaphragm end into a flowing cool water bath.

- 5780 and 5781 female halves: Water level should be halfway up the nut and the nut hex fully immersed.
- 5782 and 5783 male halves: Water level should fully cover the threads.

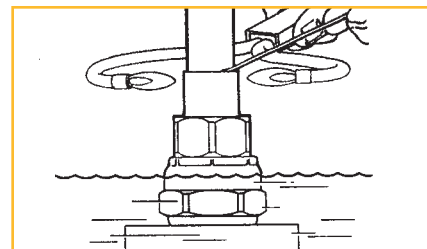

## Step 3

Use a double tip torch to promote even heating and reduce braze time.



## Step 4

After the alloy solidifies, quench the tubing and coupling to reduce the temperature below 400°F. Make sure the water does not enter the open charge port in the 5781 or 5783 half.

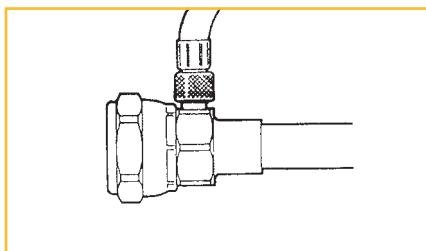

## Step 5

The couplings can be subjected to unit test pressures up to 300 psig. If pressures in excess of 300 psig are used, the protector caps and plugs should be installed.

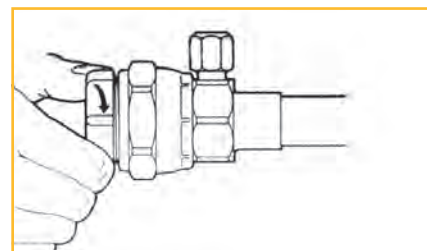

## Step 6

Protector caps and plugs should be installed finger tight. Overtightening can damage the diaphragm. The diaphragm and O-ring can be lubricated with refrigerant oil prior to installing the protector caps or plugs as added assurance of proper lubrication when connected at unit installation.

## Male-Half Installation Procedure

Male half (5782) should be mounted with the hex on the inside of the unit held in place with the appropriate mounting flange. Sheet metal opening, screw hole diameter, and mounting bolt circle dimensions are included in the chart below.

Coupling Part Number	Coupling Hex Size	Recommended Sheet Metal Opening		Flange Part Number	Mounting Bolt Circle		Screw Hole Diameter	
		Inches	mm		Inches	mm	Inches	mm
5782-Size-6	3/4"	0.656	16.6	5700-22-6	1.44	36.5	0.201	5.10
5782-Size-6	3/4"	0.656	16.6	5706-22-6	1.44	36.5	0.153	3.88
5782-Size-10	1-1/16"	1.094	27.7	FD57-1110-10	1.69	42.9	0.201	5.10
5782-Size-10	1-1/16"	1.094	27.7	FD67-1008-12	1.69	42.9	0.153	3.88
5782-Size-11	1-1/8"	1.156	29.3	150-22-8	1.69	42.9	0.201	5.10
5782-Size-11	1-1/8"	1.156	29.3	5700-22-10	1.69	42.9	0.153	3.88
5782-Size-12	1-7/16"	1.469	37.3	FD57-1110-12	2.12	53.8	0.201	5.10
5782-Size-12	1-7/16"	1.469	37.6	FD57-1111-12	2.12	53.8	0.153	3.88

# Line-Set Field Installation Instructions

## Step 1

Apply refrigerant oil to the entire surface of diaphragm, o-ring, and threaded area of male coupling assembly. The amount of lubricant used must cover all designated surfaces sufficiently. Ideal application is a small applicator brush saturated with lubricant and applied liberally. An alternate lubricant for this application is a refrigerant compatible silicone grease product like Dow Corning DC200/60,000 cst.

## Step 2

Ensure that the coupling halves are held in proper alignment with each other prior to starting the threads of the female coupling nut onto the male half. The coupling end faces should be parallel with each other and visually in line with each other, this allows the female

coupling nut to be easily threaded on by hand for the initial 2-3 rotation of the union nut. These initial rotations will bring the diaphragm in contact and a sharp increase in torque will be felt when they come into contact.

**If the nut will not start by hand, adjust the position of the line set to ensure proper coupling alignment and eliminate/minimize all side-load force on the coupling during assembly.**

## Step 3

Using appropriate size wrenches, reference table below for the female coupling body and female union nut, tighten the female union nut while preventing rotation of the female body with respect to the male half. The nut should be tightened until a definite increase in resistance, metal to metal contact occurs, is felt (at

this point, the nut will have covered most of the threads on the male body). It is important to ensure the male and female coupling bodies **DO NOT ROTATE** during any portion of the wrench installation.

## Step 4

Using a permanent marker or scribe, mark a line lengthwise from the female coupling union nut to either the bulkhead or female coupling body. Then tighten an additional one (1) wrench flat (60°); refer to the marking on the union nut to confirm the rotation has occurred. This final rotation is necessary to ensure the formation of the leak-proof seal, between the male and female couplings.

## Step 5

Repeat step 1 through 4 for all connections.

Size Designation	Torque Values Union Nut Min-Max		Male Coupling Hex Size		Female Coupling Union Nut Hex Size		Female Coupling Body Hex Size	
	Ft. Lbs	N.m	Inches	mm	Inches	mm	Inches	mm
-06	10-12	13.5 - 16.2	3/4	19.05	13/16	17.46	5/8	15.87
-10	35-45	47.5 - 61.0	1-1/16	26.98	1-5/16	33.33	1	25.40
-11	35-45	47.5 - 61.0	1-1/8	28.57	1-5/16	46.55	1	25.40
-12	50-65	67.8 - 88.1	1-7/16	36.51	1-11/16	34.9	1-3/8	42.86

# Reconnection Instructions

**Note:** The O-ring is only an intermediate seal during the initial connection of a precharged unit/line set combination. The O-ring is only used for sealing between the time the diaphragm is pierced and the final metal-to-metal seal is made.

The final leak-proof seal is a metal-to-metal connection made between the male and female coupling bodies.

## Step 1

Upon disconnection, remove O-ring.

## Step 2

If O-ring is missing from groove, insure O-ring is not lodged inside coupling halves and reconnect without O-ring.

## Step 3

Carefully wipe coupling seats and threaded surfaces with a clean cloth, to prevent the inclusion of dirt or any foreign material in the system.

## Step 4

Lubricate male half diaphragm with system-compatible refrigerant oil. Thread coupling halves together by hand to insure proper mating of threads. Use proper size wrenches (on coupling body hex and on union nut) and tighten until

## Order Options

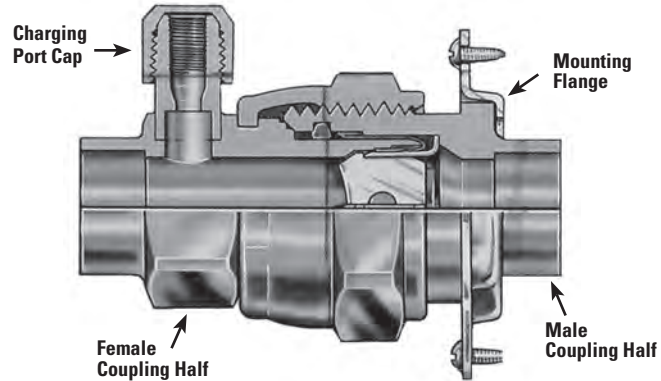

coupling bodies seat or seal or a definite resistance is felt.

## Step 5

Using a marker, mark a line lengthwise from the coupling union nut to the bulkhead. Then tighten an additional one (1) wrench flat (60°); the misalignment of the line will show the amount the coupling has been tightened. This final rotation is necessary to insure the formation of a leakproof joint.

If a torque wrench is used, the following torque values are recommended:

Coupling Size	Ft - Lbs	N.m
-6	10 - 12	13.5 - 16.2
-10	35 - 45	47.5 - 61.0
-11	35 - 45	47.5 - 61.0
-12	55 - 65	74.6 - 88.1

Basic Coupling Size	O.D. Tube Size Inches	Female Coupling Half without Charging Port (Includes Plug)	Female Coupling Half with Charging Valve Port less Cap and Core (Includes Plug)	Male Coupling Half with Protector Cap less Mounting Flange	Male Coupling Half with Charging Valve Port less Cap and Core (Includes Plug)	Mounting Flanges for 5782 Couplings Only		Charging Port Cap	Charging Valve Core
						Bolt Hole Dia. 0.15 (#10 Screw)	Bolt Hole Port (#14 Screw)		
-6	1/4	5780-4-6	5781-4-6	5782-4-6	5783-4-6	5706-22-6	5700-22-6	221014-4B	222034-4
-6	5/16	5780-5-6	5781-5-6	5782-5-6	—	5706-22-6	5700-22-6	221014-4B	222034-4
-6	3/8	5780-6-6	5781-6-6	5782-6-6	5783-6-6	5706-22-6	5700-22-6	221014-4B	222034-4
-10	1/2	5780-8-10	5781-8-10	5782-8-10	5783-8-10	FD67-1008-12	FD57-1111-10	221014-4B	222034-4
-10	5/8	5780-10-10	5781-10-10	5782-10-10	—	FD67-1008-12	FD57-1111-10	221014-4B	222034-4
-10	3/4	5780-12-10	5781-12-10	5782-12-10	5783-12-10	FD67-1008-12	FD57-1111-10	221014-4B	222034-4
-11	1/2	5780-8-11	5781-8-11	5782-8-11	5783-8-11	5700-22-10	150-22-8	221014-4B	222034-4
-11	5/8	5780-10-11	5781-10-11	5782-10-11	—	5700-22-10	150-22-8	221014-4B	222034-4
-11	3/4	5780-12-11	5781-12-11	5782-12-11	5783-12-11	5700-22-10	150-22-8	221014-4B	222034-4
-11	7/8	5780-14-11	5781-14-11	5782-14-11	5783-14-11	5700-22-10	150-22-8	221014-4B	222034-4
-12	3/4	5780-12-12	5781-12-12	5782-12-12	—	FD57-1111-12	FD57-1110-12	221014-4B	222034-4
-12	7/8	5780-14-12	5781-14-12	5782-14-12	—	FD57-1111-12	FD57-1110-12	221014-4B	222034-4
-12	1-1/8	5780-18-12	5781-18-12	5782-18-12	—	FD57-1111-12	FD57-1110-12	221014-4B	222034-4



# FD57 Series Stub Kit Couplings

Parker's FD57 series stub kit couplings combine the 5700 series couplings with unique copper connections. The additional copper creates a drop-in replacement and allows copper-to-copper brazing.

## Application

- Factory precharged heat pump and split-type air conditioning systems.

## Base Product Part Number

- FD57 - XXXX - Copper size - coupling size

## Features and Benefits

- Easy installation of replacement units.
- Direct copper braze capability.

## Agency Approvals

UL Recognized;  
File No. SA7511

## Style A

### 5780 Series Coupling with Straight/Belled Copper Configuration

Part Number	Dimensions – Inches					
	Thread T	A Ref.	B Ref.	C Ref.	D Ref.	E Ref.
FD57-1127-04-06	5/8"-18	4.09	0.81	0.31	0.25	0.62
FD57-1127-06-06	5/8"-18	4.09	0.81	0.31	0.38	0.62
FD57-1127-08-10	1-1/16"-12	5.28	1.31	0.38	0.50	1.00
FD57-1127-08-11	1-1/8"-12	5.32	1.31	0.38	0.50	1.00

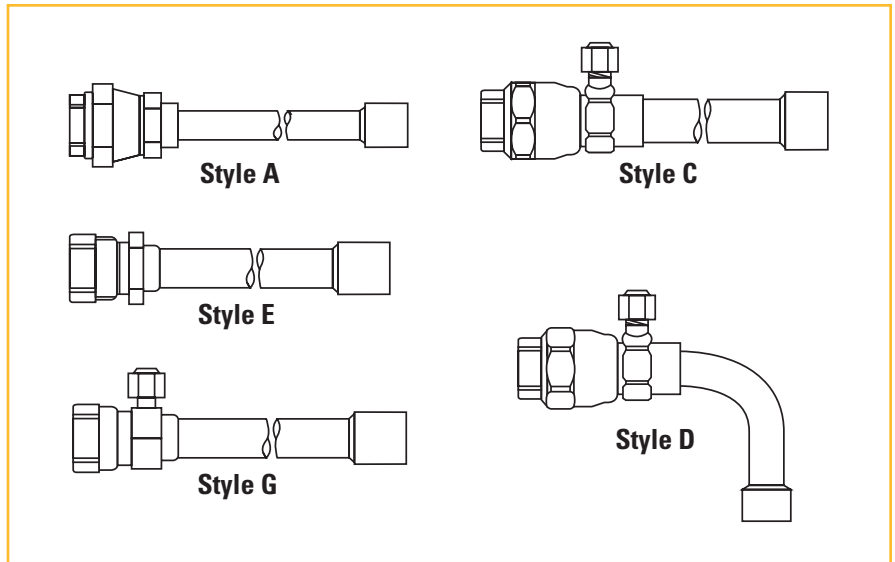
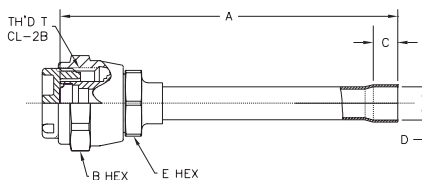
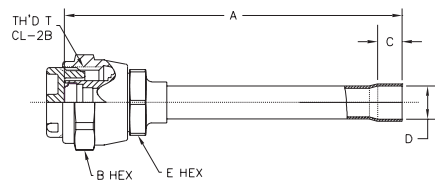

# Dimensions

## Style C

### 5781 Series Coupling with Straight/Belled Copper Configuration

Part Number	Thread T	Dimensions – Inches				
		A Ref.	B Ref.	C Ref.	D Ref.	E Ref.
FD57-1084-06-06	5/8"-18	7.42	0.81	0.75	0.375	0.62
FD57-1084-10-10	1-1/16"-12	7.86	1.31	0.75	0.625	1.00
FD57-1084-14-11	1-1/8"-12	8.00	1.31	0.75	0.875	1.00
FD57-1084-12-11	1-1/8"-12	7.96	1.31	0.75	0.750	1.00
FD57-1084-10-11	1-1/8"-12	7.90	1.31	0.75	0.625	1.00
FD57-1129-04-06	5/8"-18	4.34	0.81	0.31	0.25	0.62
FD57-1129-05-06	5/8"-18	4.34	0.81	0.31	0.31	0.62
FD57-1129-06-06	5/8"-18	4.34	0.81	0.31	0.38	0.62
FD57-1129-08-10	1-1/16"-12	5.53	1.31	0.38	0.50	1.00
FD57-1129-10-10	1-1/16"-12	5.98	1.31	0.50	0.62	1.00
FD57-1129-10-11	1-1/8"-12	6.02	1.31	0.50	0.62	1.00
FD57-1129-12-11	1-1/8"-12	6.08	1.31	0.62	0.75	1.00
FD57-1129-12-12	1-7/16"-12	6.38	1.69	0.62	0.75	1.38
FD57-1129-14-11	1-1/8"-12	6.09	1.31	0.75	0.88	1.00
FD57-1129-14-12	1-7/16"-12	6.39	1.69	0.75	0.88	1.38
FD57-1129-18-11	1-1/8"-12	6.09	1.31	0.91	1.12	1.00
FD57-1147-06-06	5/8"-18	4.34	0.81	0.31	0.38	0.62
FD57-1147-06-11	1-1/8"-12	4.50	1.31	0.31	0.38	1.00
FD57-1147-08-10	1-1/16"-12	5.53	1.31	0.38	0.50	1.00

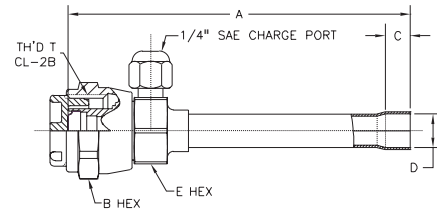

## Style D

### 5781 Series Coupling with Bent/Belled Copper Configuration

Part Number	Thread T	Dimensions – Inches					
		A Ref.	B Ref.	C Ref.	D Ref.	E Ref.	F Ref.
FD57-1130-06-06	5/8"-18	2.55	0.81	2.16	0.31	0.38	0.62
FD57-1130-08-10	1-1/16"-12	3.06	1.31	2.94	0.38	0.50	1.00
FD57-1130-10-10	1-1/16"-12	3.11	1.31	3.34	0.50	0.62	1.00
FD57-1145-10-11	1-1/8"-12	3.15	1.31	3.34	0.50	0.62	1.00
FD57-1145-14-11	1-1/8"-12	3.81	1.31	2.97	0.75	0.88	1.00
FD57-1148-06-06	5/8"-18	2.55	0.81	2.16	0.31	0.38	0.62
FD57-1148-08-10	1-1/16"-12	3.06	1.31	2.94	0.38	0.50	1.00

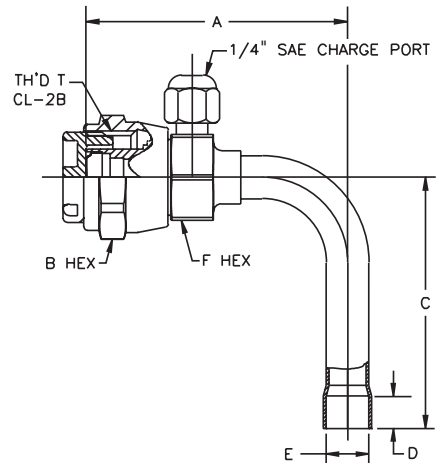

# Dimensions

## Style E

### 5782 Series Coupling with Straight/Belled Copper Configuration

Part Number	Thread T	Dimensions – Inches			
		A Ref.	B Ref.	C Ref.	D Ref.
FD57-1115-06-06	5/8"-18	7.08	0.75	0.75	0.375
FD57-1115-10-11	1-1/8"-12	7.54	1.12	0.75	0.625
FD57-1131-04-06	5/8"-18	4.00	0.75	0.31	0.25
FD57-1131-05-06	5/8"-18	4.00	0.75	0.31	0.31
FD57-1131-06-06	5/8"-18	4.00	0.75	0.31	0.38
FD57-1131-08-10	1-1/16"-12	5.09	1.06	0.38	0.50
FD57-1131-10-10	1-1/16"-12	5.55	1.06	0.50	0.62
FD57-1131-10-11	1-1/8"-12	5.66	1.12	0.50	0.62
FD57-1131-14-11	1-1/8"-12	5.72	1.12	0.75	0.88
FD57-1131-14-12	1-1/16"-12	5.89	1.44	0.75	0.88
FD57-1146-06-06	5/8"-18	3.14	0.75	0.38	0.38
FD57-1146-06-11*	1-1/8"-12	3.30	1.30	0.38	1.12
FD57-1146-08-10*	1-1/16"-12	3.37	1.06	0.50	0.50

\* No Bell.

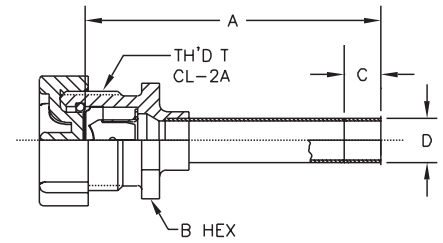

## Style G

### 5783 Series Coupling with Straight/Belled Copper Configuration

Part Number	Thread T	Dimensions – Inches			
		A Ref.	B Ref.	C Ref.	D Ref.
FD57-1133-06-06	5/8"-18	4.25	0.62	0.31	0.38
FD57-1133-10-11	1-1/8"-12	5.96	1.12	0.5	0.62
FD57-1133-12-11	1-1/8"-12	5.96	1.12	0.62	0.75
FD57-1133-14-11	1-1/8"-12	5.94	1.12	0.75	0.88

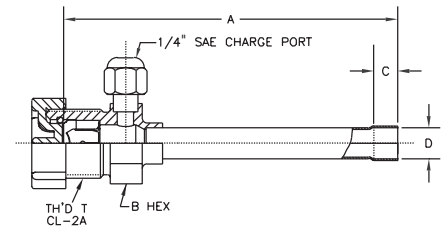

# RC01C Series Automotive R134a Service Coupling

Parker's RC01C automotive service coupling provides easy evacuating and charging of HFC-134a mobile air conditioning systems.

## Application

- Evacuating and charging of HFC-134a air conditioning systems

## Base Product Part Number

- **RC01C-002**  
Lowside field service coupling
- **RC01C-003**  
Highside field service coupling

\*See the following page for brass and plated part numbers and configurations.

## Features and Benefits

- Safety feature prevents coupling from flowing unless connected to service port.
- Brass coupling, with or without plating, provides corrosion resistance.
- Red anodized knob on the high side and blue anodized knob on the low side, along with distinct sizes, assist in preventing cross-contamination between sections of the system.

## Specifications

Temperature Rating: -40°F to +250°F  
-40°C to +121°C

Maximum Operating Pressure: 500 psig

## Agency Approvals

SAEJ639



# Dimensions

## RC01C-002 Service Coupling Assembly Low Side, R134a

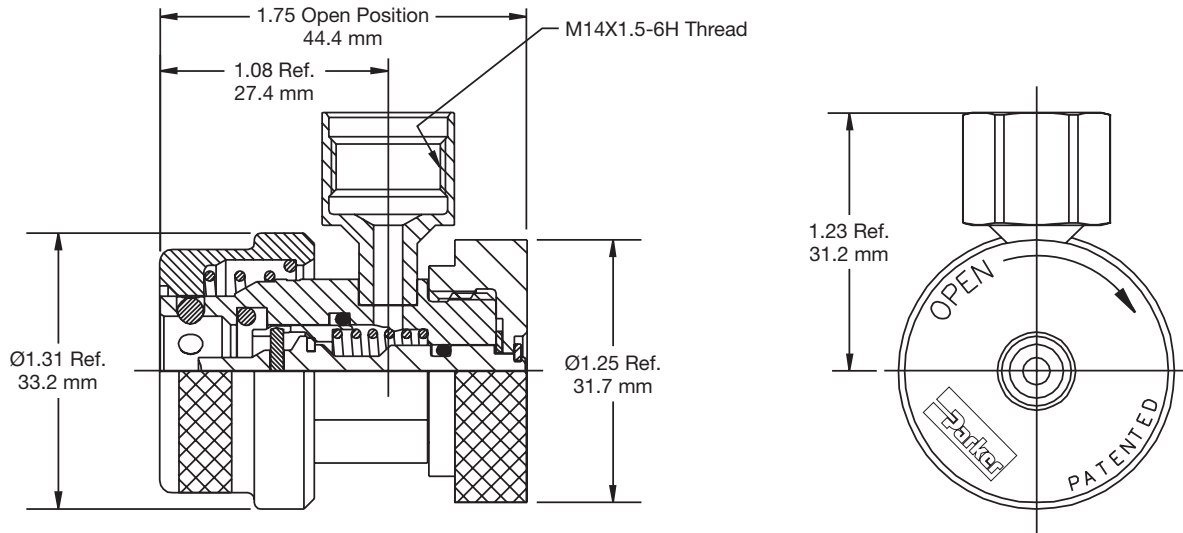

## RC01C-003 Service Coupling Assembly High Side, R134a

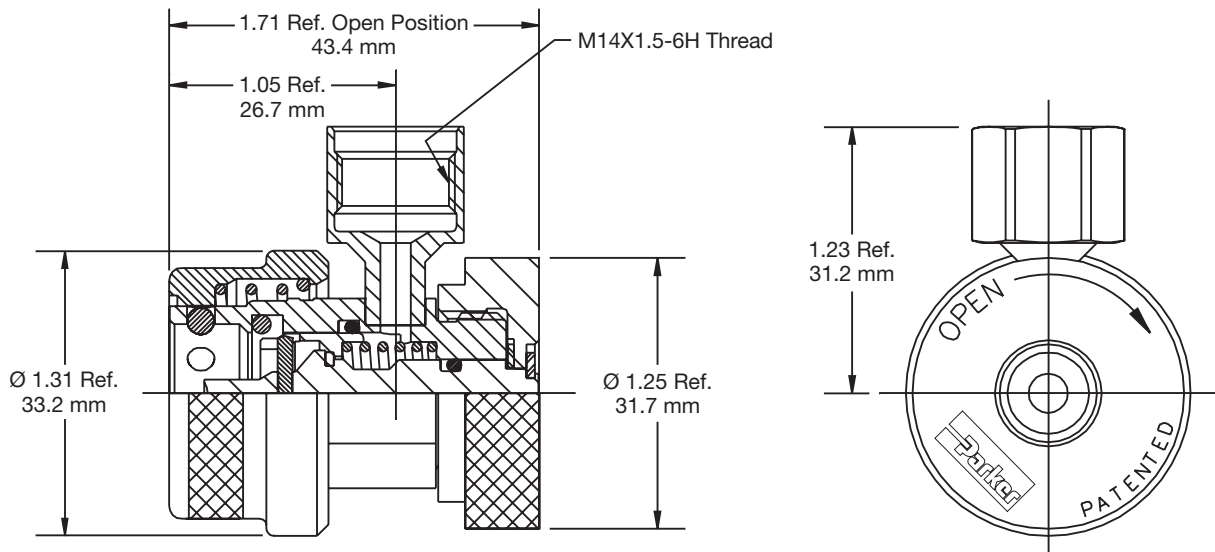

Finish	Side Port	System Side	Part Number
Plated	14 mm Female	Low Side	RC01C-002
Plated	14 mm Female	High Side	RC01C-003
Plated	5/8" - 18 Male	Low Side	RC01C-006
Plated	5/8" - 18 Male	High Side	RC01C-007
Plated	7/16" - 20 Male	Low Side	RC01C-011
Plated	7/16" - 20 Male	High Side	RC01C-012

Finish	Side Port	System Side	Part Number
Brass	14 mm Female	Low Side	RC01C-021
Brass	14 mm Female	High Side	RC01C-022
Brass	7/16" - 20 Male	Low Side	RC01C-023
Brass	7/16" - 20 Male	High Side	RC01C-024

## Repair Kits

- Nose Seal Repair Kit, Part Number RA0122-001
- RC01B001-08-01 Process Coupling, Part Number RA0203-001

# RC01YF Series Automotive 1234YF Service Coupling

Parker's RC01YF automotive service coupling provides easy evacuating and charging of HFO-1234yf mobile air conditioning systems.

## Application

- Evacuating and charging of HFO-1234yf air conditioning systems

## Base Product Part Number

- **RC01YF-012**  
Lowside field service coupling
- **RC01YF-013**  
Highside field service coupling

\*See the following page for brass and plated part numbers and configurations.

## Features and Benefits

- Safety feature prevents coupling from flowing unless connected to service port.
- Brass coupling with plating, provides corrosion resistance.
- Red anodized knob and sleeve on the high side and blue anodized knob and sleeve on the low side assist in preventing cross-contamination between sections of the system.
- Lock-out feature that prevents actuation until the coupler is securely locked into place on the charge port.

## Specifications

Temperature Rating: -40°F to +250°F  
-40°C to 121°C

Maximum Operating Pressure: 500 psig

## Agency Approvals

SAEJ2888 and SAEJ639



# Dimensions

## RC01YF-012 Service Coupling Assembly Low Side, R1234yf

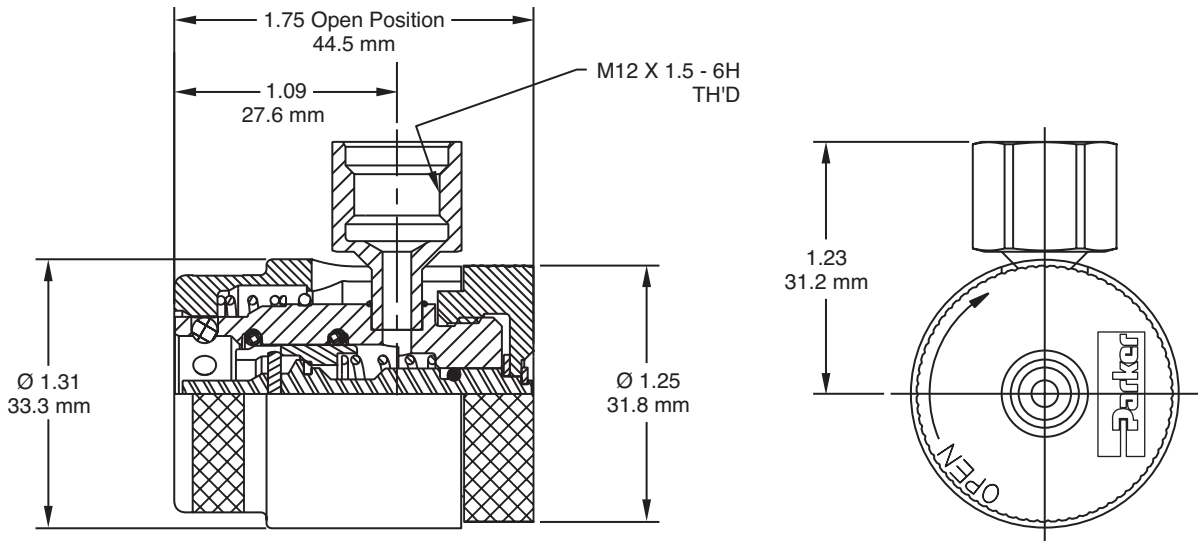

## RC01YF-013 Service Coupling Assembly High Side, R1234yf

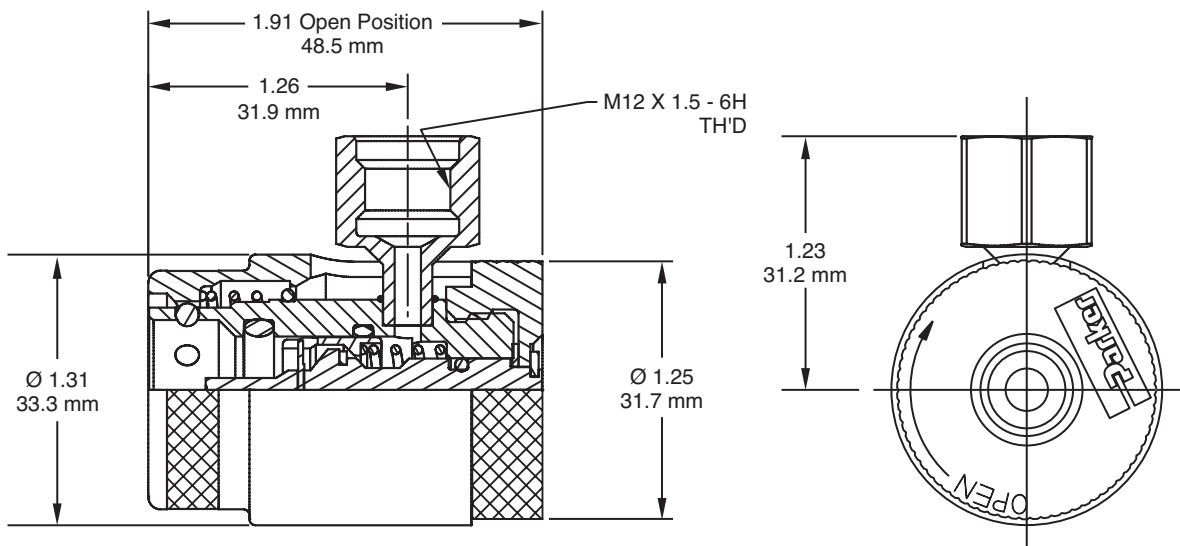

Finish	Side Port	System Side	Part Number
Plated	12 mm Female	Low Side	RC01YF-012
Plated	12 mm Female	High Side	RC01YF-013

## Repair Kits

- Nose Seal Repair Kit, Part Number RA0575-001

## OFFER OF SALE

The items described in this document and other documents and descriptions provided by Parker Hannifin Corporation, its subsidiaries and its authorized distributors ("Seller") are hereby offered for sale at prices to be established by Seller. This offer and its acceptance by any customer ("Buyer") shall be governed by all of the following Terms and Conditions. Buyer's order for any item described in its document, when communicated to Seller verbally, or in writing, shall constitute acceptance of this offer. All goods or work described will be referred to as "Products".

1. **Terms and Conditions.** Seller's willingness to offer Products, or accept an order for Products, to or from Buyer is expressly conditioned on Buyer's assent to these Terms and Conditions and to the terms and conditions found on-line at [www.parker.com/saleterms/](http://www.parker.com/saleterms/). Seller objects to any contrary or additional term or condition of Buyer's order or any other document issued by Buyer.

2. **Price Adjustments; Payments.** Prices stated on the reverse side or preceding pages of this document are valid for 30 days. After 30 days, Seller may change prices to reflect any increase in its costs resulting from state, federal or local legislation, price increases from its suppliers, or any change in the rate, charge, or classification of any carrier. The prices stated on the reverse or preceding pages of this document do not include any sales, use, or other taxes unless so stated specifically. Unless otherwise specified by Seller, all prices are F.O.B. Seller's facility, and payment is due 30 days from the date of invoice. After 30 days, Buyer shall pay interest on any unpaid invoices at the rate of 1.5% per month or the maximum allowable rate under applicable law.

3. **Delivery Dates; Title and Risk; Shipment.** All delivery dates are approximate and Seller shall not be responsible for any damages resulting from any delay. Regardless of the manner of shipment, title to any products and risk of loss or damage shall pass to Buyer upon tender to the carrier at Seller's facility (i.e., when it's on the truck, it's yours). Unless otherwise stated, Seller may exercise its judgment in choosing the carrier and means of delivery. No deferral of shipment at Buyer's request beyond the respective dates indicated will be made except on terms that will indemnify, defend and hold Seller harmless against all loss and additional expense. Buyer shall be responsible for any additional shipping charges incurred by Seller due to Buyer's changes in shipping, product specifications or in accordance with Section 13, herein.

4. **Warranty.** Seller warrants that the Products sold hereunder shall be free from defects in material or workmanship for a period of twelve months from the date of delivery to Buyer or 2,000 hours of normal use, whichever occurs first. This warranty is made only to Buyer and does not extend to anyone to whom Products are sold after purchased from Seller. The prices charged for Seller's products are based upon the exclusive limited warranty stated above, and upon the following disclaimer: **DISCLAIMER OF WARRANTY: THIS WARRANTY COMPRISES THE SOLE AND ENTIRE WARRANTY PERTAINING TO PRODUCTS PROVIDED HEREUNDER. SELLER DISCLAIMS ALL OTHER WARRANTIES, EXPRESS AND IMPLIED, INCLUDING MERCHANTABILITY AND FITNESS FOR A PARTICULAR PURPOSE.**

5. **Claims; Commencement of Actions.** Buyer shall promptly inspect all Products upon delivery. No claims for shortages will be allowed unless reported to the Seller within 10 days of delivery. No other claims against Seller will be allowed unless asserted in writing within 60 days after delivery or, in the case of an alleged breach of warranty, within 30 days after the date within the warranty period on which the defect is or should have been discovered by Buyer. Any action based upon breach of this agreement or upon any other claim arising out of this sale (other than an action by Seller for any amount due to Seller from Buyer) must be commenced within thirteen months from the date of tender of delivery by Seller or, for a cause of action based upon an alleged breach of warranty, within thirteen months from the date within the warranty period on which the defect is or should have been discovered by Buyer.

6. **LIMITATION OF LIABILITY.** UPON NOTIFICATION, SELLER WILL, AT ITS OPTION, REPAIR OR REPLACE A DEFECTIVE PRODUCT, OR REFUND THE PURCHASE PRICE. **IN NO EVENT SHALL SELLER BE LIABLE TO BUYER FOR ANY SPECIAL, INDIRECT, INCIDENTAL OR CONSEQUENTIAL DAMAGES ARISING OUT OF, OR AS THE RESULT OF, THE SALE, DELIVERY, NON-DELIVERY, SERVICING, USE OR LOSS OF USE OF THE PRODUCTS OR ANY PART THEREOF, OR FOR ANY CHARGES OR EXPENSES OF ANY NATURE INCURRED WITHOUT**

**SELLER'S WRITTEN CONSENT, EVEN IF SELLER HAS BEEN NEGLIGENT, WHETHER IN CONTRACT, TORT OR OTHER LEGAL THEORY. IN NO EVENT SHALL SELLER'S LIABILITY UNDER ANY CLAIM MADE BY BUYER EXCEED THE PURCHASE PRICE OF THE PRODUCTS.**

7. **Contingencies.** Seller shall not be liable for any default or delay in performance if caused by circumstances beyond the reasonable control of Seller.

8. **User Responsibility.** The user, through its own analysis and testing, is solely responsible for making the final selection of the system and Product and assuring that all performance, endurance, maintenance, safety and warning requirements of the application are met. The user must analyze all aspects of the application and follow applicable industry standards and Product information. If Seller provides Product or system options, the user is responsible for determining that such data and specifications are suitable and sufficient for all applications and reasonably foreseeable uses of the Products or systems.

9. **Loss to Buyer's Property.** Any designs, tools, patterns, materials, drawings, confidential information or equipment furnished by Buyer or any other items which become Buyer's property, may be considered obsolete and may be destroyed by Seller after two consecutive years have elapsed without Buyer placing an order for the items which are manufactured using such property. Seller shall not be responsible for any loss or damage to such property while it is in Seller's possession or control.

10. **Special Tooling.** A tooling charge may be imposed for any special tooling, including without limitation, dies, fixtures, molds and patterns, acquired to manufacture Products. Such special tooling shall be and remain Seller's property notwithstanding payment of any charges by Buyer. In no event will Buyer acquire any interest in apparatus belonging to Seller which is utilized in the manufacture of the Products, even if such apparatus has been specially converted or adapted for such manufacture and notwithstanding any charges paid by Buyer. Unless otherwise agreed, Seller shall have the right to alter, discard or otherwise dispose of any special tooling or other property in its sole discretion at any time.

11. **Buyer's Obligation; Rights of Seller.** To secure payment of all sums due or otherwise, Seller shall retain a security interest in the goods delivered and this agreement shall be deemed a Security Agreement under the Uniform Commercial Code. Buyer authorizes Seller as its attorney to execute and file on Buyer's behalf all documents Seller deems necessary to perfect its security interest. Seller shall have a security interest in, and lien upon, any property of Buyer in Seller's possession as security for the payment of any amounts owed to Seller by Buyer.

12. **Improper use and Indemnity.** Buyer shall indemnify, defend, and hold Seller harmless from any claim, liability, damages, lawsuits, and costs (including attorney fees), whether for personal injury, property damage, patent, trademark or copyright infringement or any other claim, brought by or incurred by Buyer, Buyer's employees, or any other person, arising out of: (a) improper selection, improper application or other misuse of Products purchased by Buyer from Seller; (b) any act or omission, negligent or otherwise, of Buyer; (c) Seller's use of patterns, plans, drawings, or specifications furnished by Buyer to manufacture Product; or (d) Buyer's failure to comply with these terms and conditions. Seller shall not indemnify Buyer under any circumstance except as otherwise provided.

13. **Cancellations and Changes.** Orders shall not be subject to cancellation or change by Buyer for any reason, except with Seller's written consent and upon terms that will indemnify, defend and hold Seller harmless against all direct, incidental and consequential loss or damage. Seller may change product features, specifications, designs and availability with notice to Buyer.

14. **Limitation on Assignment.** Buyer may not assign its rights or obligations under this agreement without the prior written consent of Seller.

15. **Entire Agreement.** This agreement constitutes the entire agreement between the Buyer and Seller and constitutes the final, complete and exclusive

expression of the terms of the agreement. All prior or contemporaneous written or oral agreements or negotiations with respect to the subject matter are herein merged.

16. **Waiver and Severability.** Failure to enforce any provision of this agreement will not waive that provision nor will any such failure prejudice Seller's right to enforce that provision in the future. Invalidation of any provision of this agreement by legislation or other rule of law shall not invalidate any other provision herein. The remaining provisions of this agreement will remain in full force and effect.

17. **Termination.** This agreement may be terminated by Seller for any reason and at any time by giving Buyer thirty (30) days written notice of termination. In addition, Seller may by written notice immediately terminate this agreement for the following: (a) Buyer commits a breach of any provision of this agreement (b) the appointment of a trustee, receiver or custodian for all or any part of Buyer's property (c) the filing of a petition for relief in bankruptcy of the other Party on its own behalf, or by a third party (d) an assignment for the benefit of creditors, or (e) the dissolution or liquidation of the Buyer.

18. **Governing Law.** This agreement and the sale and delivery of all Products hereunder shall be deemed to have taken place in and shall be governed and construed in accordance with the laws of the State of Ohio, as applicable to contracts executed and wholly performed therein and without regard to conflicts of laws principles. Buyer irrevocably agrees and consents to the exclusive jurisdiction and venue of the courts of Cuyahoga County, Ohio with respect to any dispute, controversy or claim arising out of or relating to this agreement. Disputes between the parties shall not be settled by arbitration unless, after a dispute has arisen, both parties expressly agree in writing to arbitrate the dispute.

19. **Indemnity for Infringement of Intellectual Property Rights.** Seller shall have no liability for infringement of any patents, trademarks, copyrights, trade dress, trade secrets or similar rights except as provided in this Section. Seller will defend and indemnify Buyer against allegations of infringement of U.S. patents, U.S. trademarks, copyrights, trade dress and trade secrets ("Intellectual Property Rights"). Seller will defend at its expense and will pay the cost of any settlement or damages awarded in an action brought against Buyer based on an allegation that a Product sold pursuant to this Agreement infringes the Intellectual Property Rights of a third party. Seller's obligation to defend and indemnify Buyer is contingent on Buyer notifying Seller within ten (10) days after Buyer becomes aware of such allegations of infringement, and Seller having sole control over the defense of any allegations or actions including all negotiations for settlement or compromise. If a Product is subject to a claim that it infringes the Intellectual Property Rights of a third party, Seller may, at its sole expense and option, procure for Buyer the right to continue using the Product, replace or modify the Product so as to make it noninfringing, or offer to accept return of the Product and return the purchase price less a reasonable allowance for depreciation. Notwithstanding the foregoing, Seller shall have no liability for claims of infringement based on information provided by Buyer, or directed to Products delivered hereunder for which the designs are specified in whole or part by Buyer, or infringements resulting from the modification, combination or use in a system of any Product sold hereunder. The foregoing provisions of this Section shall constitute Seller's sole and exclusive liability and Buyer's sole and exclusive remedy for infringement of Intellectual Property Rights.

20. **Taxes.** Unless otherwise indicated, all prices and charges are exclusive of excise, sales, use, property, occupational or like taxes which may be imposed by any taxing authority upon the manufacture, sale or delivery of Products.

21. **Equal Opportunity Clause.** For the performance of government contracts and where dollar value of the Products exceed \$10,000, the equal employment opportunity clauses in Executive Order 11246, VEVRAA, and 41 C.F.R. §§ 60-1.4(a), 60-741.5(a), and 60-250.4, are hereby incorporated.









